

ARTESYN AVE350B-48S28 SERIES

350 Watts Half brick Converter



PRODUCT DESCRIPTION

Advanced Energy’s Artesyn AVE350B-48S28 is a single output DC/DC converter with standard half-brick form factor and pin configuration. It delivers up to 12.5A output current with 28V output. Above 93.5% ultra-high efficiency and excellent thermal performance makes it an ideal choice to supply power to a power amplifier used in telecom and datacom applications. With the aluminium baseplate it can work under $-40\text{ }^{\circ}\text{C} \sim +85\text{ }^{\circ}\text{C}$ without air cooling.

SPECIAL FEATURES

- Delivering up to 12.5A output
- Ultra-high efficiency 93.5% typ. at full load
- Wide input range: 36V to 75V
- Excellent thermal performance
- No minimum load requirement
- RoHS 3.0
- Remote control logic optional
- Remote output sense
- Trim function: 60% ~ 118%
- Input under voltage lockout
- Output over current protection
- Output over voltage protection
- Over temperature protection
- Industry standard half-brick pin-out outline
- With baseplate
- Pin length optional
- Remote control logic optional

SAFETY

- TUV-SUD EN 62368-1
- UL+CUL UL 60950-1
- CE EN 62368-1

TYPICAL APPLICATIONS

- Telecom/ Datacom

AT A GLANCE

Total Power

350 Watts

Input Voltage

36 to 75 Vac

of Outputs

Single



MODEL NUMBERS

| Standard | Output Voltage | Structure | Remote ON/OFF logic | RoHS Status |
|-------------------|----------------|-----------|---------------------|-------------|
| AVE350B-48S28-6 | 28Vdc | Baseplate | Negative | RoHS 3.0 |
| AVE350B-48S28P-6L | 28Vdc | Baseplate | Positive | RoHS 3.0 |

Ordering Information

| | | | | | | | | | |
|---------|---|----|---|----|---|---|---|---|---|
| AVE350B | - | 48 | S | 28 | P | - | 6 | L | M |
| ① | | ② | ③ | ④ | ⑤ | | ⑥ | ⑦ | ⑧ |

| | | |
|---|----------------------|--|
| ① | Model series | AVE: high efficiency half-brick series, 350: output power 350W |
| ② | Input voltage | 48: 36V ~ 75V input range, rated input voltage 48V |
| ③ | Output number | S: single output |
| ④ | Rated output voltage | 28: 28V output |
| ⑤ | Remote ON/OFF logic | Default: negative; P: positive logic |
| ⑥ | Pin length | 6: 3.8mm pin length |
| ⑦ | RoHS status | L: RoHS 3.0 |
| ⑧ | Mounting hole | Default: through hole; M: screw thread |

Options

None

ELECTRICAL SPECIFICATIONS

Absolute Maximum Ratings

Stress in excess of those listed in the “Absolute Maximum Ratings” may cause permanent damage to the power supply. These are stress ratings only and functional operation of the unit is not implied at these or any other conditions above those given in the operational sections of this TRN. Exposure to any absolute maximum rated condition for extended periods may adversely affect the power supply’s reliability

| Table 1. Absolute Maximum Ratings | | | | | | |
|-----------------------------------|-----------------------|-------------|------|-----|------|------|
| Parameter | Model | Symbol | Min | Typ | Max | Unit |
| Input Voltage | Operating -Continuous | $V_{IN,DC}$ | - | - | 80 | Vdc |
| | Non-operating -100mS | | - | - | 100 | Vdc |
| Maximum Output Power | All | $P_{O,max}$ | - | - | 350 | W |
| Isolation Voltage ¹ | All | | - | - | 1500 | Vdc |
| | | | - | - | 1500 | Vdc |
| | | | - | - | 500 | Vdc |
| Ambient Operating Temperature | All | T_A | -40 | - | +85 | °C |
| Storage Temperature | All | T_{STG} | -55 | - | +125 | °C |
| Voltage at remote ON/OFF pin | All | | -0.3 | - | 15 | Vdc |
| Humidity (non-condensing) | All | | - | - | 95 | % |
| | | | - | - | 95 | |

Note 1 - 1mA for 60s, slew rate of 1500V/10s

ELECTRICAL SPECIFICATIONS

Input Specifications

| Table 2. Input Specifications | | | | | | |
|--|---|------------------|-----|--------------|------|--------------------------|
| Parameter | Condition ¹ | Symbol | Min | Typ | Max | Unit |
| Operating Input Voltage, DC | All | $V_{IN,DC}$ | 36 | 48 | 75 | Vdc |
| Turn-on Voltage Threshold | $I_O = I_{O,max}$ | $V_{IN,ON}$ | 33 | 35 | 36 | Vdc |
| Turn-off Voltage Threshold | $I_O = I_{O,max}$ | $V_{IN,OFF}$ | 31 | 33 | 35 | Vdc |
| Lockout Voltage Hysteresis | $I_O = I_{O,max}$ | | 1 | 2 | 3 | V |
| Maximum Input Current ($I_O = I_{O,max}$) | $V_{IN,DC} = 36V_{DC}$ | $I_{IN,max}$ | - | 10.5 | 11.5 | A |
| No-load input current | | $I_{IN,no-load}$ | - | 0.035 | - | A |
| Standby Input current | Remote OFF | $I_{IN,standby}$ | - | 0.001 | - | A |
| Recommended Input Fuse | Fast blow external fuse recommended | | - | - | 15 | A |
| Input filter component values (C\L) | Internal values | | | 7\0.68 | | $\mu F \backslash \mu H$ |
| Recommended External Input Capacitance | Low ESR capacitor recommended | C_{IN} | - | 220 | - | μF |
| Input Reflected Ripple Current | Through 12 μH inductor | | - | 35 | - | mA |
| Operating Efficiency | $T_A = 25^\circ C$ $I_O = I_{O,max}$ $I_O = 50\% I_{O,max}$ | η | - | 93.5 93.2 | - | % % |

Note 1 - $T_A = 25^\circ C$, airflow rate = 400 LFM, $V_{in} = 48V_{dc}$, nominal V_{out} unless otherwise noted. All electrical specification is guaranteed above 35V input voltage after module turn on.

ELECTRICAL SPECIFICATIONS

Output Specifications

| Table 3. Output Specifications | | | | | | | |
|---|--|-------------------------------------|--------------------|------|-------|----------------|-----------|
| Parameter | Condition | Symbol | Min | Typ | Max | Unit | |
| Factory Set Voltage | $V_{IN,DC} = 48V_{DC}$ $I_O = 50\%I_{O,max}$ | V_O | 27.72 | 28 | 28.28 | Vdc | |
| Output Voltage Line Regulation | All | $\%V_O$ | - | 0.05 | 1 | % | |
| Output Voltage Load Regulation | All | $\%V_O$ | - | 0.1 | 1 | % | |
| Output Voltage Temperature Regulation | All | $\%V_O$ | - | 0.01 | 0.02 | $\%/^{\circ}C$ | |
| Total output voltage range (Over sample, line, load, temperature & life) | All | V_O | 27.16 | 28 | 28.84 | V | |
| Output Voltage Trim Range | All | $\%V_O$ | 60 | - | 118 | % | |
| Output voltage remote sense range | All | | - | - | 0.5 | V | |
| Output Ripple, pk-pk | 20MHz bandwidth | V_O | - | 120 | 200 | mV_{PK-PK} | |
| Output Current | | I_O | 0 | - | 12.5 | A | |
| Output DC current-limit inception ² | | I_O | 13.125 | - | 17.5 | A | |
| V_O Load Capacitance ³ | High frequency and low ESR are recommended | C_O | 680 | 750 | 4000 | μF | |
| V_O Dynamic Response | Peak Deviation Settling Time | 50% ~75%~50% slew rate = 0.1A/us | $\pm V_O$ T_s | - | 210 | 840 | mV |
| | | | | - | - | 500 | μSec |
| Turn-on transient | Rise time | $I_O = I_{O,max}$ | T_{rise} | | 16 | 100 | mS |
| | Turn-on delay time | $I_O = I_{O,max}$ | $T_{turn-on}$ | - | 17 | 50 | mS |
| | Output voltage overshoot | $I_O = 0$ | $\%V_O$ | - | 0 | - | % |
| Switching frequency | All | f_{sw} | - | 285 | - | KHz | |
| Remote ON/OFF control (positive logic) | Off-state voltage | All | | -0.3 | - | 0.8 | V |
| | On-state voltage | All | | 2.4 | - | 15 | V |
| Remote ON/OFF control (Negative logic) | Off-state voltage | All | | 2.4 | - | 15 | V |
| | On-state voltage | All | | -0.3 | - | 0.8 | V |
| Output over-voltage protection ⁴ | All | $\%V_O$ | 115 | - | 140 | % | |
| Output over-temperature protection ⁵ | All | T | 105 | 115 | 125 | $^{\circ}C$ | |
| Over-temperature hysteresis | All | T | 5 | - | - | $^{\circ}C$ | |
| MTBF | Normal input/output Bellcore, TR332 method 1, case 3 | | - | 2 | - | 10^6 h | |

Note 1 - $T_a = 25^{\circ}C$, airflow rate = 400 LFM, $V_{in} = 48V_{dc}$, nominal V_{out} unless otherwise noted. All electrical specification is guaranteed above 35V input voltage after module turn on.

Note 2 - Hiccup: auto-restart when over-current condition is removed.

Note 3 - High frequency and low ESR is recommended.

Note 4 - Latch. Remain latched after OVP shutdown until power on or remote ON.

Note 5 - Auto recovery.

PERFORMANCE CURVES

AVE350B-48S28 Performance Curves

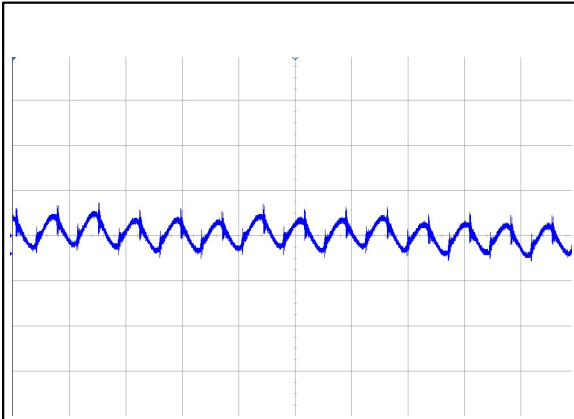

Figure 1: AVE350B-48S28 Input Reflected Ripple Current Waveform
Ch 1: I_{in} (5 μ S/div, 50mA/div)

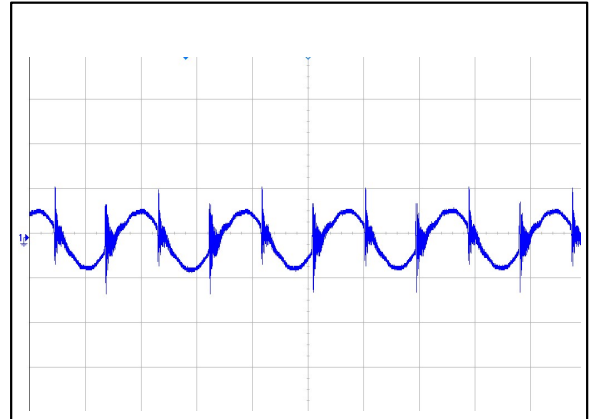

Figure 2: AVE350B-48S28 Ripple and Noise Measurement
Ch 1: V_o (2 μ S/div, 50mV/div)

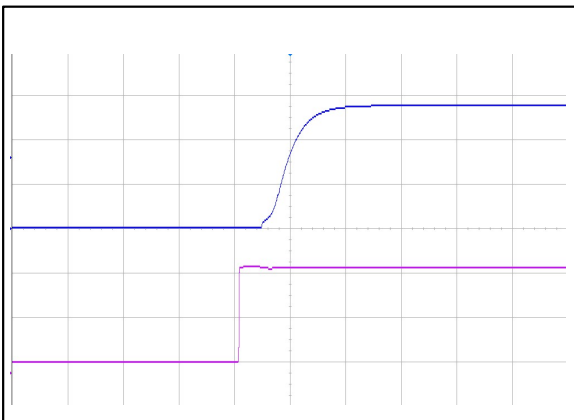

Figure 3: AVE350B-48S28 Output Voltage Startup Characteristic (20mS/div)
Ch 1: V_{in} (10V/div) Ch 2: V_o (20V/div)

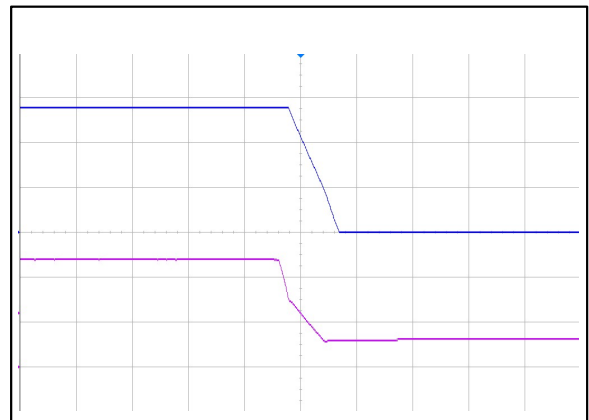

Figure 4: AVE350B-48S28 Turn Off Characteristic (5mS/div)
Ch 1: V_{in} (10V/div) Ch 2: V_o (20V/div)

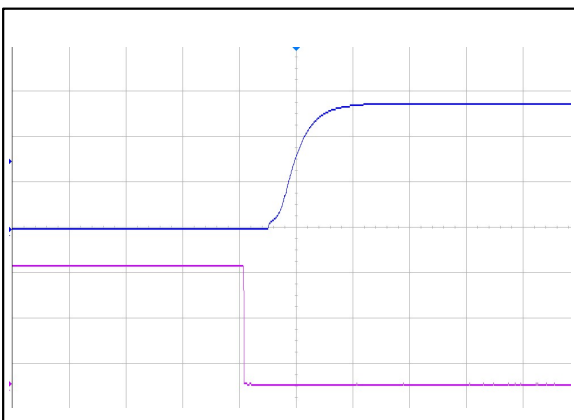

Figure 5: AVE350B-48S28 Remote ON Waveform (20mS/div)
Ch 1: Remote ON (10V/div) Ch 2: V_o (2V/div)

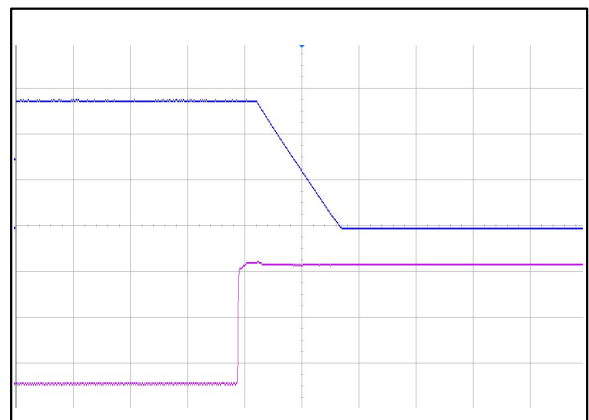

Figure 6: AVE350B-48S28 Remote OFF Waveform (1mS/div)
Ch 1: Remote OFF (10V/div) CH3: V_o (2V/div)

PERFORMANCE CURVES

AVE350B-48S28 Performance Curves

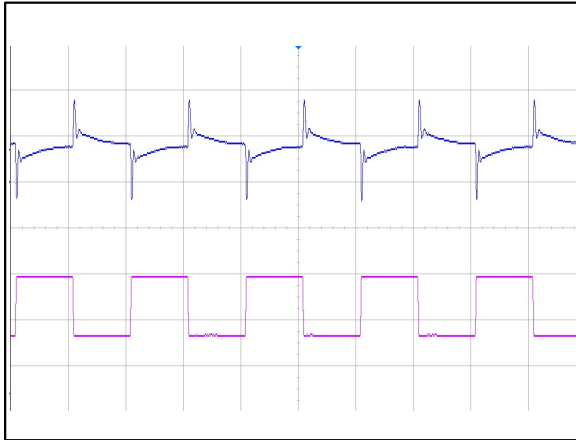

Figure 7: AVE350B-48S28 Transient Response (5mS/div)
 25%-50%-25% load change, 0.1A/uS slew rate,
 Ch 1: Vo (200mV/div) Ch 2: Io (2.5A/div)

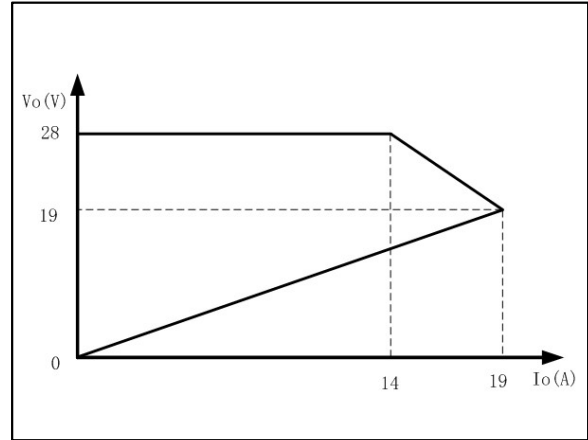

Figure 8: AVE350B-48S28 Over-current Protection Characteristics

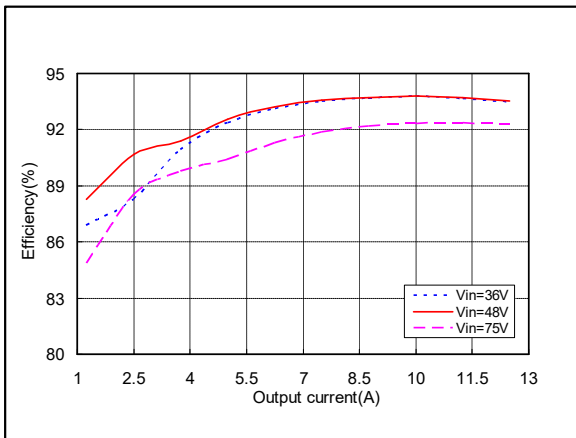
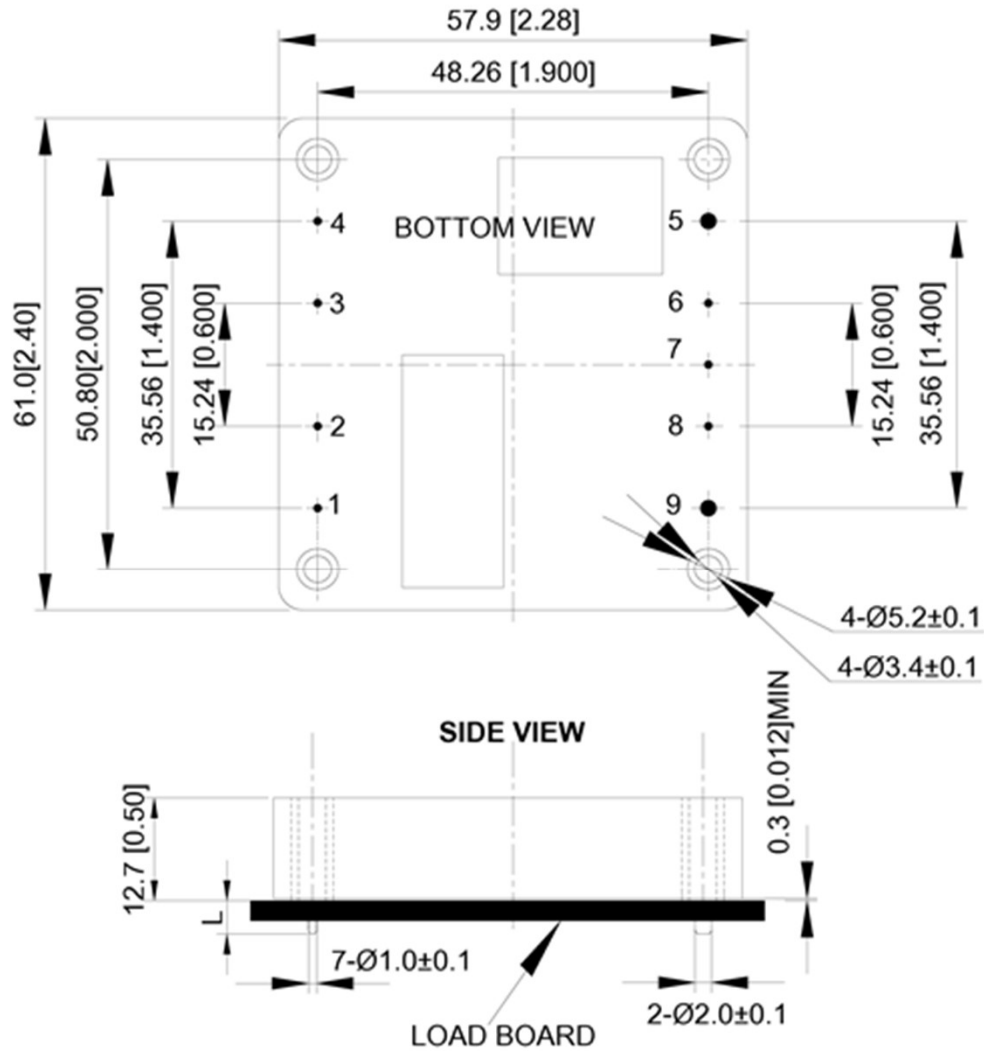

Figure 9: AVE350B-48S28 Efficiency Curves $V_o=28Vdc$

Tc: temperature test point on baseplate, $T_a=25\text{ }^\circ\text{C}$, $T_c<40\text{ }^\circ\text{C}$

MECHANICAL SPECIFICATIONS

Mechanical Outlines



UNIT: mm[inch]

BOTTOM VIEW: pin on upside

UNIT: mm[inch]

TOLERANCE: X.X mm±0.5 mm[X.XX in. ±0.02 in.]

X.XX mm±0.25 mm[X.XXX in. ±0.01 in.]

MECHANICAL SPECIFICATIONS

Pin Length Option

| Device code suffix | L |
|--------------------|----------------|
| -4 | 4.8mm ± 0.5 mm |
| -6 | 3.8mm ± 0.5 mm |
| -8 | 2.8mm ± 0.5 mm |
| None | 5.8mm ± 0.5 mm |

Pin Designations

| Pin No | Name | Function |
|--------|------|-------------------------|
| 1 | Vin+ | Positive input voltage |
| 2 | CNT | Remote ON/OFF control |
| 3 | Case | Case |
| 4 | Vin- | Negative input voltage |
| 5 | Vo- | Negative output voltage |
| 6 | S- | Negative remote sense |
| 7 | Trim | Output voltage trim |
| 8 | S+ | Positive remote sense |
| 9 | Vo+ | Positive output voltage |

ENVIRONMENTAL SPECIFICATIONS

EMC Immunity

| AVE350B-48S28 Series power supply is designed to meet the following EMC immunity specifications: | | |
|--|---|----------|
| Parameter | Condition ¹ | Criteria |
| EN55032, Class B Limits | Conducted and Radiated EMI Limits | / |
| IEC/EN 61000-4-2, Level 3 | Electromagnetic Compatibility (EMC) - Testing and measurement techniques - Electrostatic discharge immunity test. Enclosure Port | B |
| IEC/EN 61000-4-6, Level 2 | Electromagnetic Compatibility (EMC) - Testing and measurement techniques, Continuous Conducted Interference. DC input port | A |
| IEC/EN 61000-4-4, Level 3 | Electromagnetic Compatibility (EMC) - Testing and measurement techniques, Electrical Fast Transient. DC input port. | B |
| IEC/EN 61000-4-5 | Electromagnetic Compatibility (EMC) - Testing and measurement techniques, Immunity to surges - 600V common mode and 600V differential mode for DC ports | B |
| EN61000-4-29 | Electromagnetic Compatibility (EMC) - Testing and measurement techniques, Voltage Dips and short interruptions and voltage variations. DC input port | B |

Criterion A: Normal performance during and after test.

Criterion B: For EFT and surges, low-voltage protection or reset is not allowed. Temporary output voltage fluctuation ceases after disturbances ceases, and from which the EUT recovers its normal performance automatically. For Dips and ESD, output voltage fluctuation or reset is allowed during the test, but recovers to its normal performance automatically after the disturbance ceases.

Criterion C: Temporary loss of output, the correction of which requires operator intervention.

Criterion D: Loss of output which is not recoverable, owing to damage to hardware.

ENVIRONMENTAL SPECIFICATIONS

EMC Filter Configuration

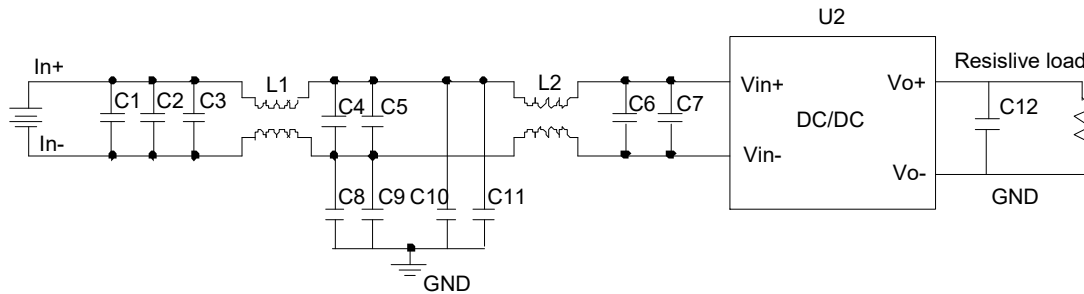

Figure 10 EMC filter configuration

U2: Module to test, AVE350B-48S28

C1 ~ C5: SMD ceramic capacitor -100V-1000nF-X7R-1210

C6: SMD ceramic capacitor -100V-100nF- $\pm 10\%$ -X7R-1206

C8 ~ C11: High-voltage CHIP ceramic capacitor. Capacitance: 0.1U/630V/X7R. Size: 2220. Capable of withstanding 1kV voltage

C7: Input electrolytic capacitor, according to the same type as C1 in Figure 14

C12: Output electrolytic capacitor, according to the same type as C4 in Figure 14

PE: Connected to output

L1, L2: Common mode inductor - single phase -473uH- $\pm 25\%$ -14A magnetic ring 1*25.4*12.7mm - working temperature range includes module temperature rise. Temperature rise at rated current: 55°C max

ENVIRONMENTAL SPECIFICATIONS

Safety Certifications

The AVE350B-48S28 Series power supply is intended for inclusion in other equipment and the installer must ensure that it is in compliance with all the requirements of the end application. This product is only for inclusion by professional installers within other equipment and must not be operated as a stand alone product.

| Table 4. Safety Certifications for AVE350B-48S28 series power supply system | | |
|---|-----------------------|----------------------------|
| Standard | File # | Description |
| UL60950, CSA-C22.2 | E132002-A104-UL - X13 | US and Canada Requirements |
| EN62368-1 | B 013890 3252 Rev. 00 | European Requirements |
| EN60950 | B 16 01 13890 02601 | International Requirements |
| CE | 1735 | CE Marking |

ENVIRONMENTAL SPECIFICATIONS

Operating Temperature

The AVE350B-48S28 series power supplies will start and operate within stated specifications at an ambient temperature from -40 °C to 85 °C under all load conditions. The storage temperature is -55 °C to 125 °C.

Thermal Considerations

The converter is designed to operate in different thermal environments and sufficient cooling must be provided.

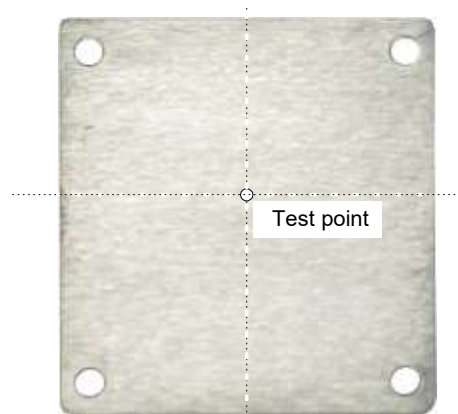

Figure 11 Temperature test points

| Test Point | Temperature limit |
|-------------------------|-------------------|
| Test point on baseplate | 105°C |

ENVIRONMENTAL SPECIFICATIONS

Application with forced air convection

The converter can also operate with a smaller heatsink and sufficient airflow. Proper cooling of the DC/DC converter can be verified by measuring the temperature at the test points, shown in Figure 12. The temperature at these points should not exceed the max values in the Table 5.

For a typical application, Figure 13 shows the derating output current vs. ambient air temperature at different air velocity with a specified heatsink (Size:L:61mm,W:58mm,H:25.4mm), shown in Figure 12.

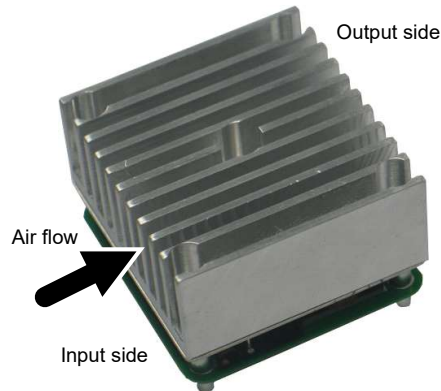

Figure 12 Typical application with a smaller heatsink and airflow

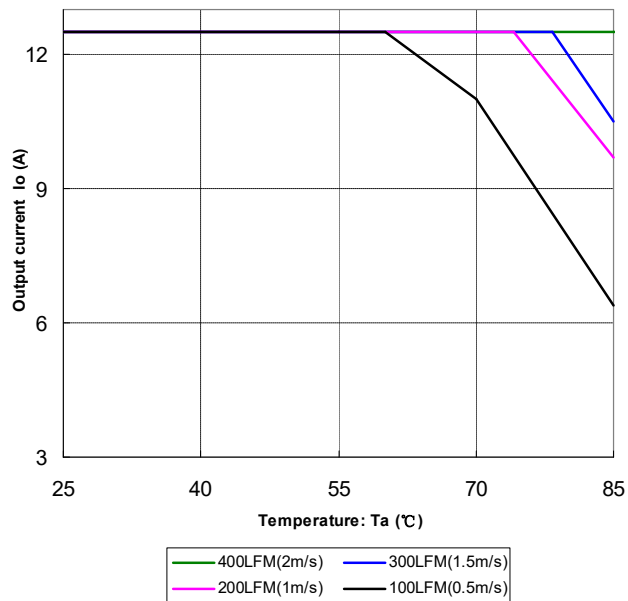

Figure 13 Output power derating, 48Vin

ENVIRONMENTAL SPECIFICATIONS

Qualification Testing

| Parameter | Unit (pcs) | Test condition |
|------------------|------------|---|
| Halt test | 4-5 | $T_{a,min} -10\text{ }^{\circ}\text{C}$ to $T_{a,max} +10\text{ }^{\circ}\text{C}$, $5\text{ }^{\circ}\text{C}$ step, V_{in} = min to max, 0 ~ 105% load |
| Vibration | 3 | Frequency range: 5Hz ~ 20Hz, 20Hz ~ 200Hz, A.S.D: $1.0\text{m}^2/\text{s}^3$, -3db/oct, axes of vibration: X/Y/Z. Time: 30min/axes |
| Mechanical Shock | 3 | 30g, 6ms, 3axes, 6directions, 3time/direction |
| Thermal Shock | 3 | -40 $^{\circ}\text{C}$ to 100 $^{\circ}\text{C}$, unit temperature 20cycles |
| Thermal Cycling | 3 | -40 $^{\circ}\text{C}$ to 55 $^{\circ}\text{C}$, temperature change rate: $1^{\circ}\text{C}/\text{min}$, cycles: 2cycles |
| Humidity | 3 | 40 $^{\circ}\text{C}$, 95%RH, 48h |
| Solder Ability | 15 | IPC J-STD-002C-2007 |

APPLICATION NOTES

Typical Application

Below is the typical application of the AVE350B-48S28 series power supply.

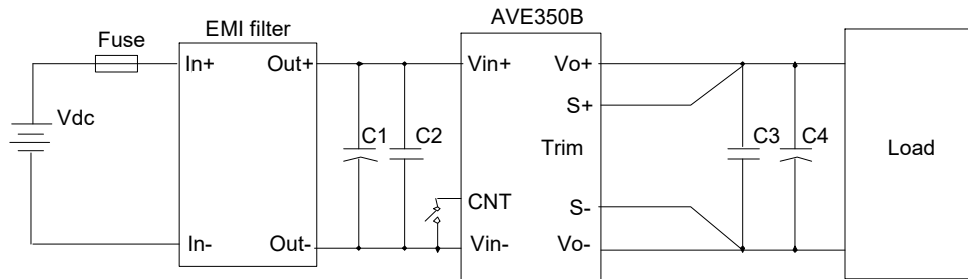

Figure 14 Typical application

C1: 220 μ F/100V electrolytic capacitor, P/N: UPM2A221MHD (Nichicon) or equivalent caps

C2, C3: 1 μ F/100V X7R ceramic capacitor, P/N: C3225X7R2A105KT0L0U (TDK) or equivalent caps

C4: 750 μ F/50V electrolytic capacitor (150 μ F*5pcs), P/N: UUD1H151MNL1GS (Nichicon) or equivalent caps

Note: If ambient temperature is below -5 $^{\circ}$ C, double input & output capacitance is necessary for normal operation and performance.

Fuse: External fast blow fuse with a rating of 15A. The recommended fuse model is 324015P from LITTELFUSE.

.

APPLICATION NOTES

Remote ON/OFF

Either positive or negative remote ON/OFF logic is available in AVE350B-48S28. The logic is CMOS and TTL compatible. Some typical applications for CNT function refer to the following figure 15.

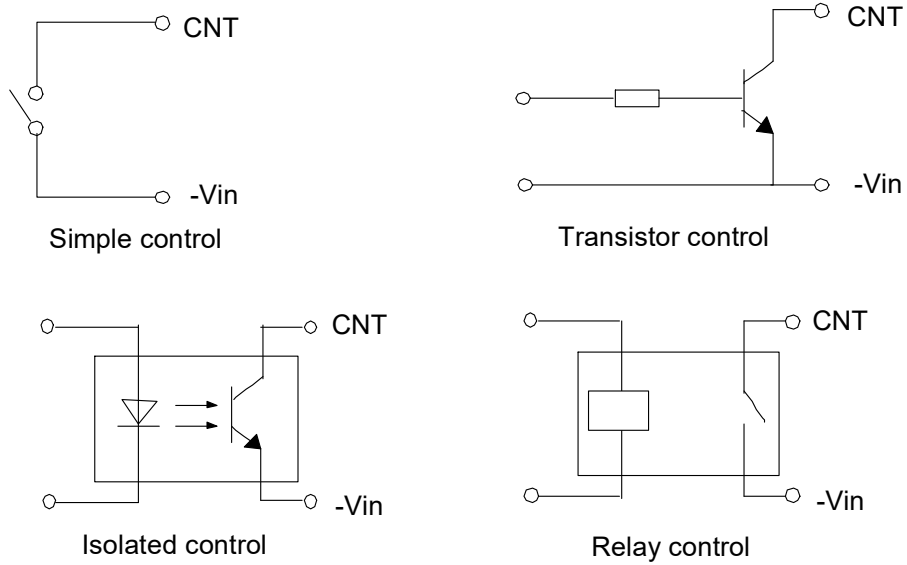

Figure 15 Remote ON/OFF internal diagram

APPLICATION NOTES

Trim Characteristics

Connecting an external resistor between Trim and Vo- will decrease the output voltage, while connecting it between Trim and Vo+ will increase the output voltage. The following equations determine the external resistance to obtain the trimmed output voltage.

$$R_{adj_down} = \left(\frac{100\%}{\Delta\%} - 2 \right) k\Omega$$

$$R_{adj_up} = \left(\frac{V_o(100\% + \Delta\%)}{1.225 \times \Delta\%} - \frac{100\% + 2 \times \Delta\%}{\Delta\%} \right) k\Omega$$

Δ : Output rate against nominal output voltage.

V_{norm} : Nominal output voltage.

For example, to get 32.2V output, the trimming resistor is

$$R_{adj_up} = \left(\frac{32.2}{1.225 \times (32.2 - 28) / 28} - \frac{100\% + 2 \times (32.2 - 28) / 28}{(32.2 - 28) / 28} \right) k\Omega = 166.57 k\Omega$$

The output voltage can also be trimmed by potential applied at the Trim pin.

$$V_o = (11.43 \times V_{trim} + 14)V$$

Where V_{trim} is the voltage applied at the trim pin and Vo-, and V_o is the desired output voltage.

When trimming up, the output current should be decreased accordingly so as not to exceed the maximum output power and the minimum input voltage should be increased as shown in the following figure 16.

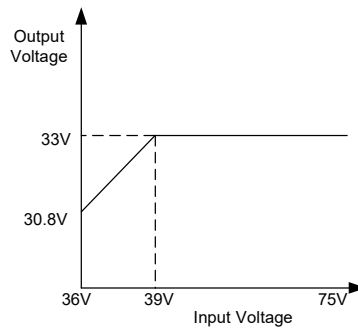

Figure 16 Max trim-up voltage vs. input voltage

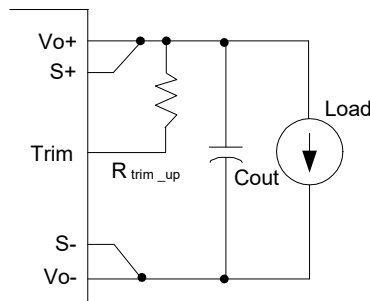

Figure 17 Trim up

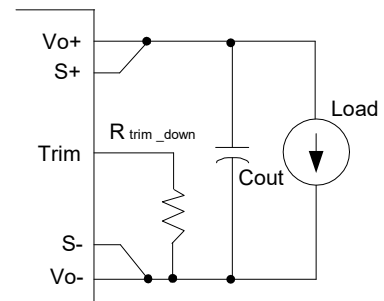

Figure 18 Trim down

APPLICATION NOTES

Sense Characteristics

If the load is far from the unit, connect S+ and S- to the terminal of the load respectively to compensate the voltage drop on the transmission line. See Figure 14 for details.

If the sense compensate function is not necessary, short S+ to Vo+ and S- to Vo- directly.

Inrush Current, Input and Output Ripple & Noise Test Configuration

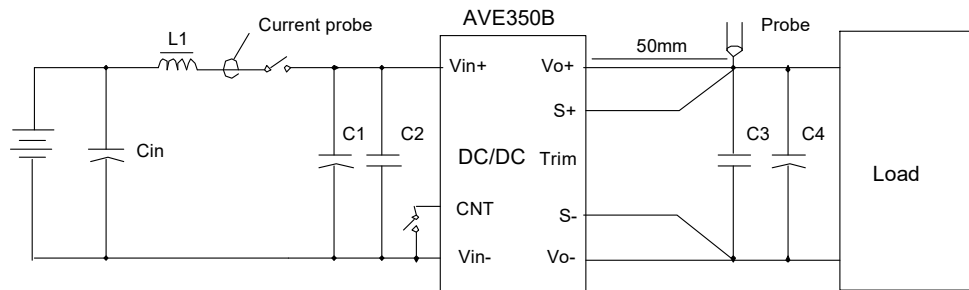

Figure 19 Input ripple & inrush current, output ripple & noise test configuration

Vdc: DC power supply

L1: 12uH inductor

Cin: 220uF/100V electrolytic capacitor

C1 ~ C4: See Figure 14

Note - Using a coaxial cable with series 50ohm resistor and 0.68uF ceramic capacitor or a ground ring of probe to test output ripple & noise is recommended.

SOLDERING INFORMATION

Soldering

The product is intended for standard manual or wave soldering.

When wave soldering is used, the temperature on pins is specified to maximum 255 °C for R5 compliant product and maximum 260 °C for R6 compliant product. And the duration must be less than 7s.

When soldering by hand, the iron temperature should be maintained at 300 °C ~ 380 °C and applied to the converter pins for less than 10s. Longer exposure can cause internal damage to the converter.

Cleaning of solder joint can be performed with cleaning solvent IPA or simulative.

RECORD OF REVISION AND CHANGES

| Issue | Date | Description | Originators |
|-------|------------|---|-------------|
| 1.0 | 07.02.2014 | First Issue | G.Xue |
| 1.1 | 10.15.2014 | Add condition | G.Xue |
| 1.2 | 09.15.2015 | Change Pin3 from “pin connected to baseplate” to “NC” | G.Xue |
| 1.3 | 03.21.2016 | Add a sentence “electrical specification is guaranteed above 35V input voltage after module turn on” at input and output section. | K. Wang |
| 1.4 | 11.01.2016 | Update the Pin tolerance | K. Wang |
| 1.5 | 11.17.2016 | Update the C7and C12 note | K. Wang |
| 1.6 | 10.13.2017 | Update the OVP mode | A. Zhang |
| 1.7 | 02.26.2020 | Update RoHS status | C.Liu |
| 1.8 | 12.08.2020 | Update Trim Range Typo | K. Wang |
| 1.9 | 07.22.2021 | Update AE template | V. Guo |



For international contact information,
visit advancedenergy.com.

powersales@aei.com (Sales Support)
productsupport.ep@aei.com (Technical Support)
+1 888 412 7832

ABOUT ADVANCED ENERGY

Advanced Energy (AE) has devoted more than three decades to perfecting power for its global customers. AE designs and manufactures highly engineered, precision power conversion, measurement and control solutions for mission-critical applications and processes.

Our products enable customer innovation in complex applications for a wide range of industries including semiconductor equipment, industrial, manufacturing, telecommunications, data center computing, and medical. With deep applications know-how and responsive service and support across the globe, we build collaborative partnerships to meet rapid technological developments, propel growth for our customers, and innovate the future of power.

PRECISION | POWER | PERFORMANCE

Specifications are subject to change without notice. Not responsible for errors or omissions. ©2020 Advanced Energy Industries, Inc. All rights reserved. Advanced Energy®, and AE® are U.S. trademarks of Advanced Energy Industries, Inc.