

ARTESYN

AEE 40W SERIES

DC/DC Converter



PRODUCT DESCRIPTION

Advanced Energy's Artesyn AEE 40W series is a latest generation of high performance dc-dc converter modules setting a new standard concerning power density. The product offers fully 40W in a shielded metal package with dimensions of just 2.0"x1.0"x 0.4". All models provide ultra-wide 4:1 input voltage range and tight output voltage regulation.

State-of-the-art circuit topology provides a very high efficiency up to 89% which allows an operating temperature range of -40 °C to +80 °C. Further features include remote On/Off, trimmable output voltage as well as overload protection and over-temperature protection.

SPECIAL FEATURES

- Smallest Encapsulated 40W Converter
- Package Size 2.0" x 1.0" x 0.4"
- Ultra-wide 4:1 input range
- Very high efficiency up to 91%
- Operating temperature range: -40 °C to +80 °C
- Over-temperature Protection
- I/O isolation voltage 1500VDC
- Remote ON/OFF control
- Shielded metal case with isolated baseplate
- 3 Years Product Warranty

SAFETY

- cUL/UL/CSA 60950-1
- IEC/EN 60950-1

TYPICAL APPLICATIONS

- Industrial

AT A GLANCE

Total Power

40 Watts

Input Voltage

9 to 36 Vdc

18 to 75 Vdc

of Outputs

Single / Dual



MODEL NUMBERS

Model	Input Voltage	Output Voltage	Maximum Load	Efficiency
AEE08F18-L	9-36Vdc	3.3V	8A	89%
AEE08A18-L	9-36Vdc	5V	8A	90%
AEE03B18-L	9-36Vdc	12V	3.33A	89%
AEE02C18-L	9-36Vdc	15V	2.67	89%
AEE01H18-L	9-36Vdc	24V	1.67A	91%
AEE01BB18-L	9-36Vdc	±12V	±1.67A	88%
AEE01CC18-L	9-36Vdc	±15 V	±1.33 A	88%
AEE08F36-L	18-75 Vdc	3.3V	8A	89%
AEE08A36-L	18-75 Vdc	5V	8A	90%
AEE03B36-L	18-75 Vdc	12V	3.33A	90%
AEE02C36-L	18-75 Vdc	15V	2.67	90%
AEE01H36-L	18-75 Vdc	24V	1.67A	91%
AEE01BB36-L	18-75 Vdc	±12 V	±1.67A	88%
AEE01CC36-L	18-75 Vdc	±15 V	±1.33 A	88%

Options

None

ELECTRICAL SPECIFICATIONS

Absolute Maximum Ratings

Stress in excess of those listed in the “Absolute Maximum Ratings” may cause permanent damage to the power supply. These are stress ratings only and functional operation of the unit is not implied at these or any other conditions above those given in the operational sections of this TRN. Exposure to any absolute maximum rated condition for extended periods may adversely affect the power supply’s reliability.

Table 1. Absolute Maximum Ratings						
Parameter	Model	Symbol	Min	Typ	Max	Unit
Input Voltage InputsurgeVoltage -100msec	24V input Models 48V input Models	$V_{IN,DC}$	-0.7 -0.7	- -	50 100	Vdc Vdc
Maximum Output Power	All	$P_{O,max}$	-	-	40	W
Isolation Voltage ¹ Input to output	All models		1500	-	-	Vdc
Isolation Resistance 500Vdc	All models		1000	-	-	Mohm
Isolation Capacitance 100KHz, 1V	All models		-	-	1500	pF
Operating Case Temperature	All	T_{CASE}	-		+105	°C
Storage Temperature	All	T_{STG}	-50		+125	°C
Humidity (non-condensing) Operating Non-operating	All All		- -	- -	95 95	% %
MTBF	MIL-STD-217F, TA =+25°C,Ground Benign		328000	-	-	Hours

Note 1 - For 60 second

ELECTRICAL SPECIFICATIONS

Input Specifications

Table 2. Input Specifications							
Parameter		Condition	Symbol	Min	Typ	Max	Unit
Operating Input Voltage, DC	24V Input Models 48V Input Models	All	$V_{IN,DC}$	9 18	24 48	36 75	Vdc
Start-up Threshold Voltage	24V Input Models 48V Input Models	All	$V_{IN,ON}$	- -	- -	9 18	Vdc
Under Voltage Lockout	24V Input Models 48V Input Models	All	$V_{IN,under}$	- -	8.3 16.5	- -	Vdc
Input reflected ripple current	24V Input Models 48V Input Models	0 to 500MHz,4.7uH source impedance	$I_{IN,ripple}$	- -	30 20	- -	mA
Input Current	AEE08F18-L AEE08A18-L AEE03B18-L AEE02C18-L AEE01H18-L AEE01BB18-L AEE01CC18-L AEE08F36-L AEE08A36-L AEE03B36-L AEE02C36-L AEE01H36-L AEE01BB36-L AEE01CC36-L	$V_{IN,DC}=V_{IN,nom}$	$I_{IN,full\ load}$	- - - - - - - - - - - - - -	1240 1850 1870 1870 1835 1890 1890 620 930 930 930 918 950 950	- - - - - - - - - - - - - -	mA
No Load Input Current (V_O On, $I_O = 0A$)	AEE08F18-L AEE08A18-L AEE03B18-L AEE02C18-L AEE01H18-L AEE01BB18-L AEE01CC18-L AEE08F36-L AEE08A36-L AEE03B36-L AEE02C36-L AEE01H36-L AEE01BB36-L AEE01CC36-L	$V_{IN,DC}=V_{IN,nom}$	I_{IN,no_load}	- - - - - - - - - - - - - -	90 90 95 105 115 65 65 55 55 60 65 75 45 45	- - - - - - - - - - - - - -	mA

ELECTRICAL SPECIFICATIONS

Input Specifications

Table 2. Input Specifications con't							
Parameter		Condition	Symbol	Min	Typ	Max	Unit
Efficiency @Max. Load	AEE08F18-L	$V_{IN,DC} = V_{IN,nom}$ $I_O = I_{O,max}$ $T_A = 25\text{ }^{\circ}\text{C}$	η	-	89	-	%
	AEE08A18-L			-	90	-	
	AEE03B18-L			-	89	-	
	AEE02C18-L			-	89	-	
	AEE01H18-L			-	91	-	
	AEE01BB18-L			-	88	-	
	AEE01CC18-L			-	88	-	
	AEE08F36-L			-	89	-	
	AEE08A36-L			-	90	-	
	AEE03B36-L			-	90	-	
	AEE02C36-L			-	90	-	
	AEE01H36-L			-	91	-	
	AEE01BB36-L			-	88	-	
AEE01CC36-L	-	88	-				
Start Up Time	Power Up	$V_{IN,DC} = V_{IN,nom}$ Constant Resistive Load		-	-	30	mS
	Remote On/Off			-	-	30	
Remote On/OFF Control		Remote ON Remote OFF		3.5 0	- -	12 1.2	Vdc
Remote Off Stand by Input Current		All		-	2.5	-	mA
Input Current of Remote Control Pin		All		-	0.5	-	mA
Internal Filter Type		All	Internal LC Filter (for EN55022,Class A)				

ELECTRICAL SPECIFICATIONS

Output Specifications

Table 3. Output Specifications							
Parameter		Condition	Symbol	Min	Typ	Max	Unit
Output Voltage Set-Point	AEE08F18-L	$V_{IN,DC} = V_{IN,nom}$ $I_O = I_{O,max}$ $T_A = 25\text{ }^\circ\text{C}$	V_O	3.27	3.3	3.33	Vdc
	AEE08A18-L			4.95	5	5.05	
	AEE03B18-L			11.88	12	12.12	
	AEE02C18-L			14.85	15	15.15	
	AEE01H18-L			23.76	24	24.24	
	AEE01BB18-L			± 11.88	± 12	± 12.12	
	AEE01CC18-L			± 14.85	± 15	± 15.15	
	AEE08F36-L			3.27	3.3	3.33	
	AEE08A36-L			4.95	5	5.05	
	AEE03B36-L			11.88	12	12.12	
	AEE02C36-L			14.85	15	15.15	
	AEE01H36-L			23.76	24	24.24	
	AEE01BB36-L			± 11.88	± 12	± 12.12	
	AEE01CC36-L			± 14.85	± 15	± 15.15	
Output Current	AEE08F18-L	Convection cooling	I_O	-	-	8	A
	AEE08A18-L			-	-	8	
	AEE03B18-L			-	-	3.33	
	AEE02C18-L			-	-	2.67	
	AEE01H18-L			-	-	1.67	
	AEE01BB18-L			-	-	± 1.67	
	AEE01CC18-L			-	-	± 1.33	
	AEE08F36-L			-	-	8	
	AEE08A36-L			-	-	8	
	AEE03B36-L			-	-	3.33	
	AEE02C36-L			-	-	2.67	
	AEE01H36-L			-	-	1.67	
	AEE01BB36-L			-	-	± 1.67	
	AEE01CC36-L			-	-	± 1.33	
V_O Load Capacitance	AEE08F18-L	All		-	-	21000	uF
	AEE08A18-L			-	-	13600	
	AEE03B18-L			-	-	2400	
	AEE02C18-L			-	-	1500	
	AEE01H18-L			-	-	600	
	AEE01BB18-L			-	-	1200	
	AEE01CC18-L			-	-	750	
	AEE08F36-L			-	-	21000	
	AEE08A36-L			-	-	13600	
	AEE03B36-L			-	-	2400	
	AEE02C36-L			-	-	1500	
	AEE01H36-L			-	-	600	
	AEE01BB36-L			-	-	1200	
	AEE01CC36-L			-	-	750	

ELECTRICAL SPECIFICATIONS

Output Specifications

Table 3. Output Specifications Con't							
Parameter		Condition	Symbol	Min	Nom	Max	Unit
Output Ripple, pk-pk	AEE08F18-L	20MHz bandwidth, measured with a 1uF MLCC and a 10uF Tantalum Capacitor	V_O	-	100	-	mV
	AEE08A18-L			-	100	-	
	AEE03B18-L			-	150	-	
	AEE02C18-L			-	150	-	
	AEE01H18-L			-	150	-	
	AEE01BB18-L			-	150	-	
	AEE01CC18-L			-	150	-	
	AEE08F36-L			-	100	-	
	AEE08A36-L			-	100	-	
	AEE03B36-L			-	150	-	
	AEE02C36-L			-	150	-	
	AEE01H36-L			-	150	-	
	AEE01BB36-L			-	150	-	
	AEE01CC36-L			-	150	-	
Output Voltage Balance	Dual outputs Modules	Dual Output, Balanced Loads	$\pm\%V_O$	-	-	2.0	%
Line Regulation	All	$V_{IN,DC} = V_{IN,min}$ to $V_{IN,max}$	$\pm\%V_O$	-	-	0.5	%
Load Regulation	Single Output	$I_O = I_{O,min}$ to $I_{O,max}$	$\pm\%V_O$	-	-	0.5	%
	Dual Output			-	-	1.0	
Load Cross Regulation	Dual Output	Asymmetrical Load 25%/100% Full Load	$\pm\%V_O$	-	-	5.0	%
Trim Range	24V Modules	All	$\%V_O$	-10		+20	%
	Other Modules	All	$\%V_O$	-10		+10	%
Switching Frequency	24V Modules	All	f_{sw}	-	285	-	KHz
	Other Modules			-	320	-	
V_O Dynamic Response	Peak Deviation Settling Time	25% load change	$\pm\%V_O$ t_s	-	3	5	% mSec
				-	250	-	
Temperature Coefficient		All	$\%/^{\circ}C$	-	-	0.02	%
Output Over Current Protection ¹		All	$\%I_{O,max}$	-	150	-	%
Output Short Circuit Protection		All		Hiccup Automatic Recovery			

Note 1 - Hiccup Automatic Recovery

ELECTRICAL SPECIFICATIONS

Output Specifications

Table 3. Output Specifications Con't							
Parameter		Condition	Symbol	Min	Typ	Max	Unit
Output Over Voltage Protection	AEE08F18-L	All	V _o	-	3.9	-	Vdc
	AEE08A18-L			-	6.2	-	
	AEE03B18-L			-	15	-	
	AEE02C18-L			-	18	-	
	AEE01H18-L			-	30	-	
	AEE01BB18-L			-	±15	-	
	AEE01CC18-L			-	±18	-	
	AEE08F36-L			-	3.9	-	
	AEE08A36-L			-	6.2	-	
	AEE03B36-L			-	15	-	
	AEE02C36-L			-	18	-	
	AEE01H36-L			-	30	-	
	AEE01BB36-L			-	±15	-	
	AEE01CC36-L			-	±18	-	

ELECTRICAL SPECIFICATIONS

AEE08F18-L Performance Curves

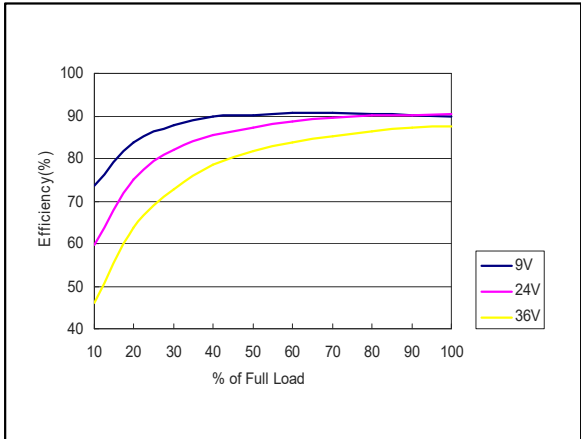

Figure 1: AEE08F18-L Efficiency Versus Output Current Curve
 Vin = 9 to 36Vdc Load: Io = 0 to 8A

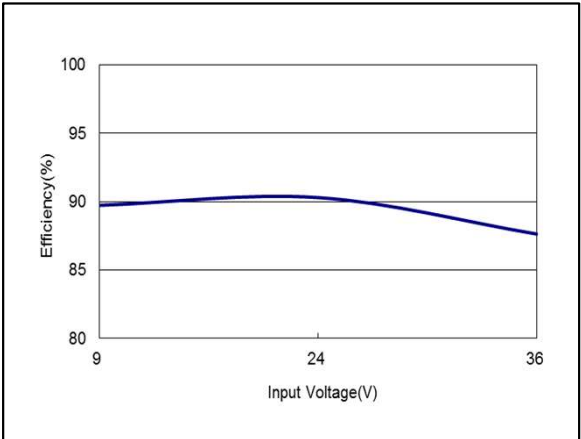

Figure 2: AEE08F18-L Efficiency Versus Input Voltage Curve
 Vin = 9 to 36Vdc Load: Io = 8A

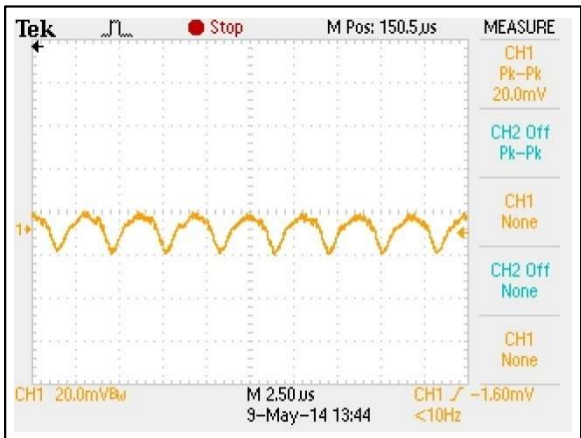

Figure 3: AEE08F18-L Ripple and Noise Measurement
 Vin = 24Vdc Load: Io = 8A
 Ch 1: Vo

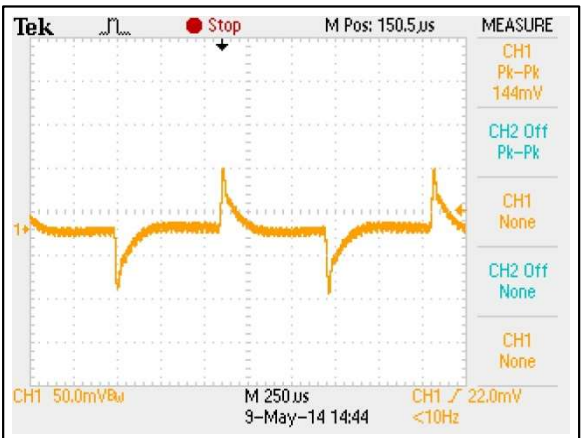

Figure 4: AEE08F18-L Transient Response
 Vin = 24Vdc Load: Io = 100% to 75% load change
 Ch 1: Vo

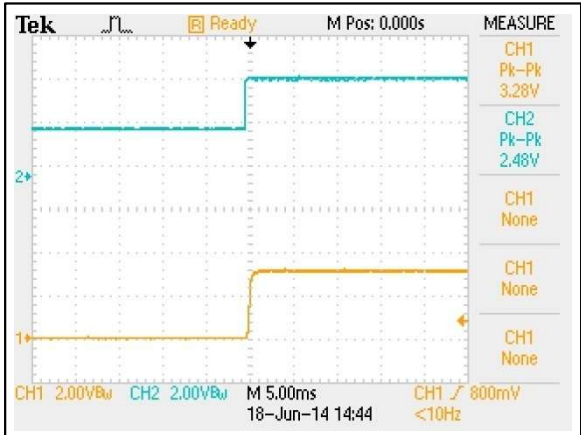

Figure 5: AEE08F18-L Output Voltage Startup Characteristic by On/Off
 Vin = 24Vdc Load: Io = 8A
 Ch 1: Vo Ch 2: Remote On/Off

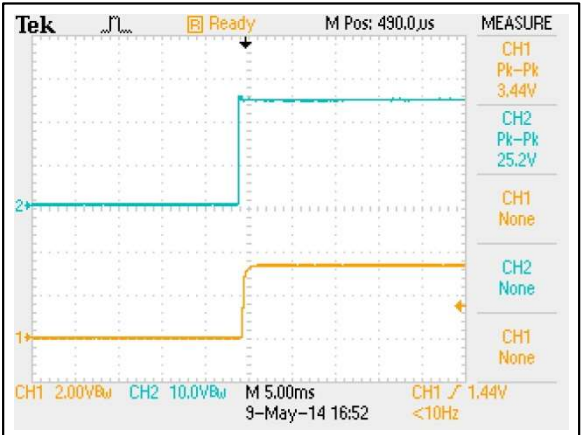

Figure 6: AEE08F18-L Output Voltage Startup Characteristic by Vin
 Vin = 24Vdc Load: Io = 8A
 Ch 1: Vo Ch 2: Vin

ELECTRICAL SPECIFICATIONS

AEE08F18-L Performance Curves

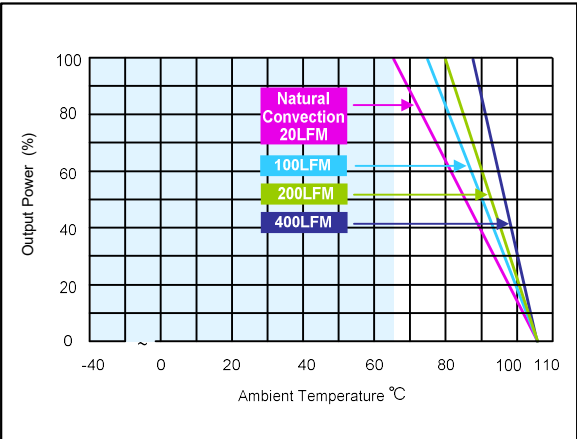

Figure 7: AEE08F18-L Derating Curves (without heatsink)
 Vin = 24Vdc Load: Io = 0 to 8A

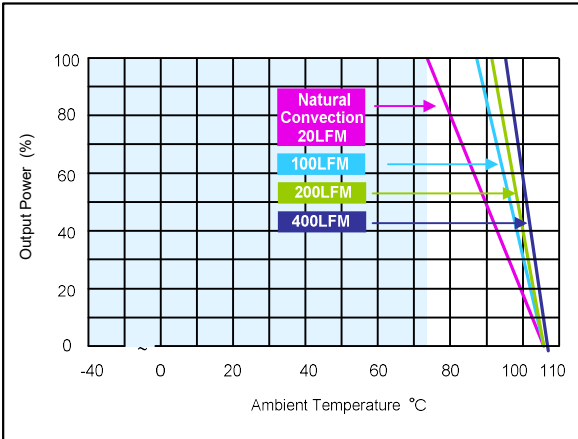

Figure 8: AEE08F18-L Derating Curves (with heatsink)
 Vin = 24Vdc Load: Io = 0 to 8A

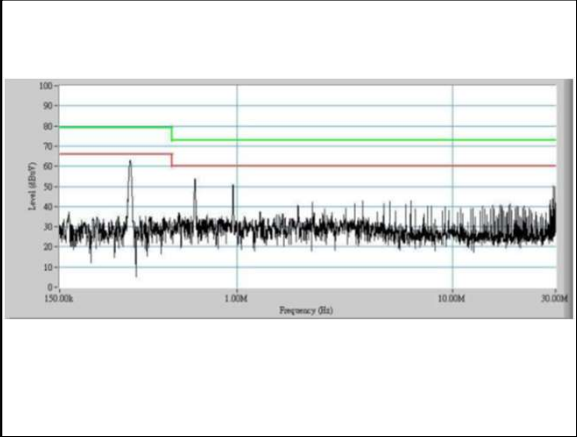

Figure 9: AEE08F18-L Conduction Emission of EN550122 Class A
 Vin = 24Vdc Load: Io = 8A

Note - All test conditions are at 25 °C

ELECTRICAL SPECIFICATIONS

AEE08A18-L Performance Curves

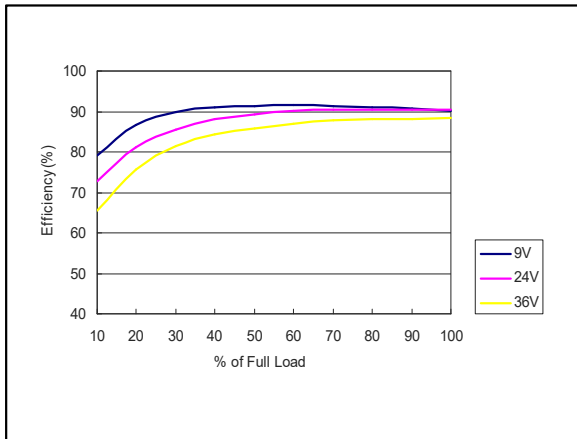

Figure 10: AEE08A18-L Efficiency Versus Output Current Curve
 Vin = 9 to 36Vdc Load: Io = 0 to 8A

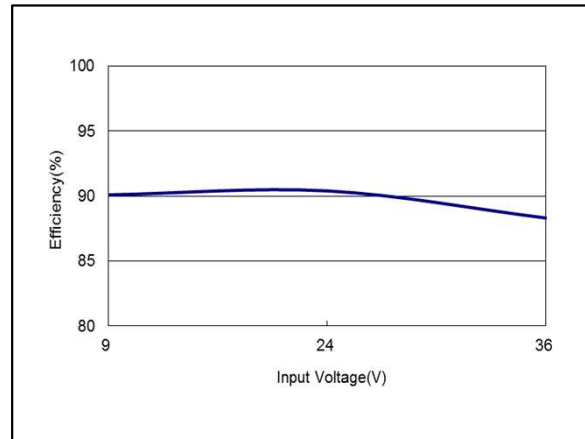

Figure 11: AEE08A18-L Efficiency Versus Input Voltage Curve
 Vin = 9 to 36Vdc Load: Io = 8A

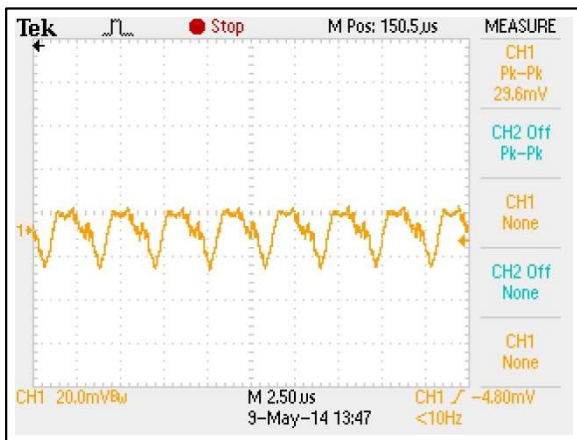

Figure 12: AEE08A18-L Ripple and Noise Measurement
 Vin = 24Vdc Load: Io = 8A
 Ch 1: Vo

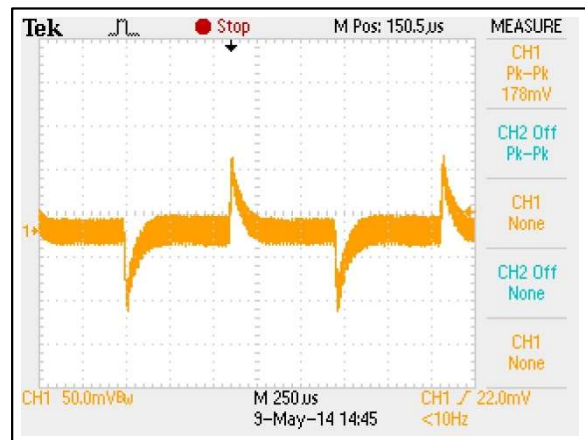

Figure 13: AEE08A18-L Transient Response
 Vin = 24Vdc Load: Io = 100% to 75% load change
 Ch 1: Vo

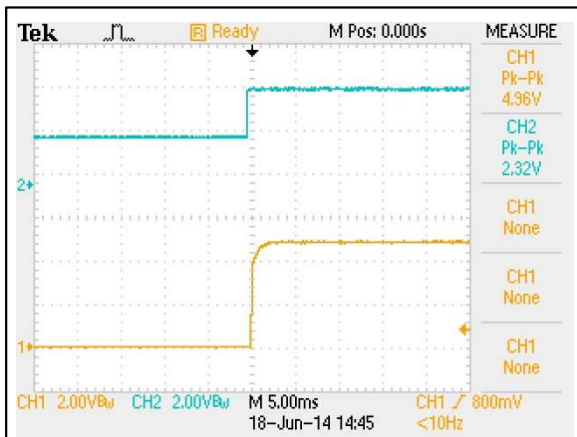

Figure 14: AEE08A18-L Output Voltage Startup Characteristic by On/Off
 Vin = 24Vdc Load: Io = 8A
 Ch 1: Vo Ch 2: Remote On/Off

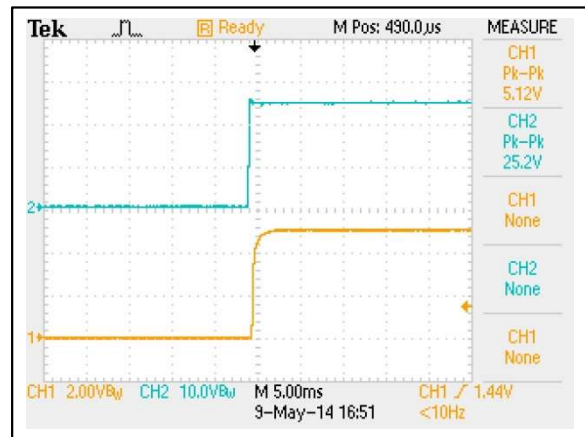

Figure 15: AEE08A18-L Output Voltage Startup Characteristic by Vin
 Vin = 24Vdc Load: Io = 8A
 Ch 1: Vo Ch 2: Vin

ELECTRICAL SPECIFICATIONS

AEE08A18-L Performance Curves

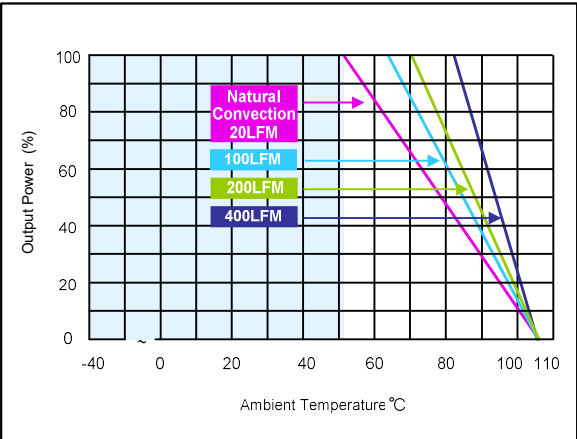

Figure 16: AEE08A18-L Derating Curves (without heatsink)
Vin = 24Vdc Load: Io = 0 to 8A

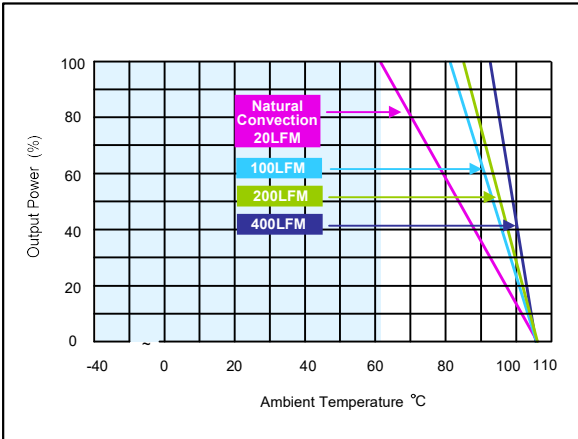

Figure 17: AEE08A18-L Derating Curves (with heatsink)
Vin = 24Vdc Load: Io = 0 to 8A

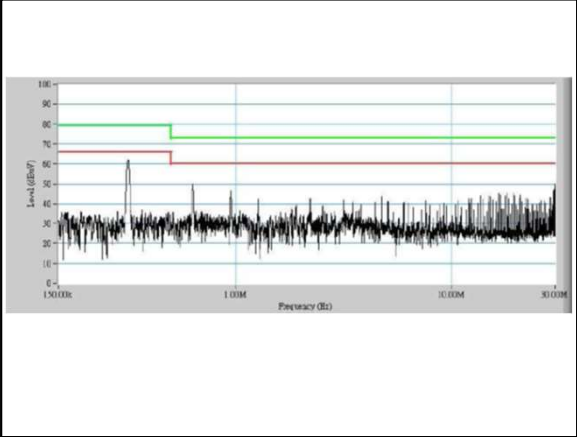

Figure 18: AEE08A18-L Conduction Emission of EN550122 Class A
Vin = 24Vdc Load: Io = 8A

Note - All test conditions are at 25 °C

ELECTRICAL SPECIFICATIONS

AEE03B18-L Performance Curves

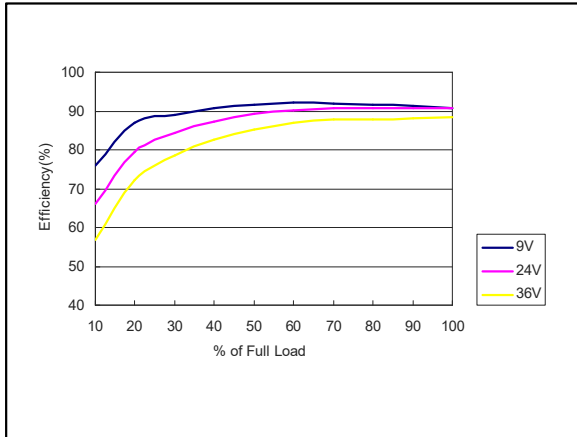

Figure 19: AEE03B18-L Efficiency Versus Output Current Curve
 Vin = 9 to 36Vdc Load: Io = 0 to 3.33A

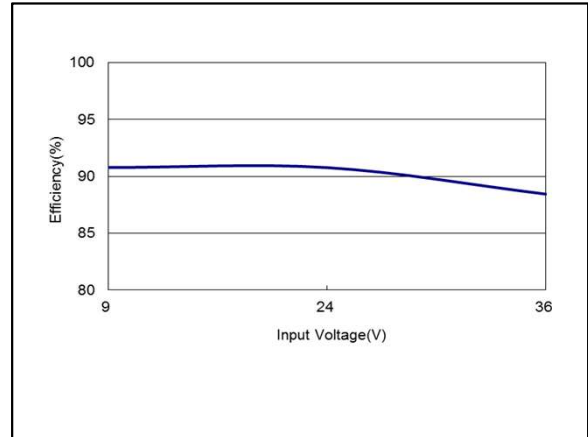

Figure 20: AEE03B18-L Efficiency Versus Input Voltage Curve
 Vin = 9 to 36Vdc Load: Io = 3.33A

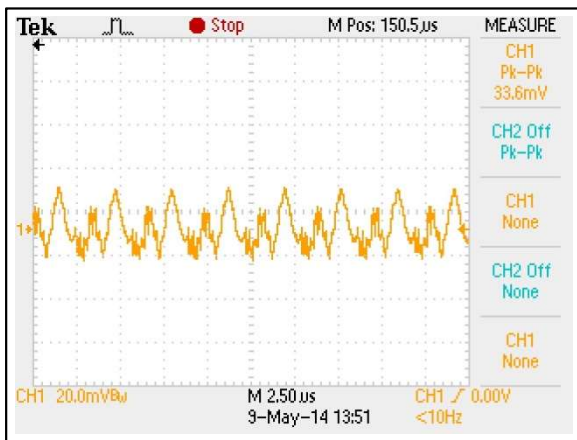

Figure 21: AEE03B18-L Ripple and Noise Measurement
 Vin = 24Vdc Load: Io = 3.33A
 Ch 1: Vo



Figure 22: AEE03B18-L Transient Response
 Vin = 24Vdc Load: Io = 100% to 75% load change
 Ch 1: Vo

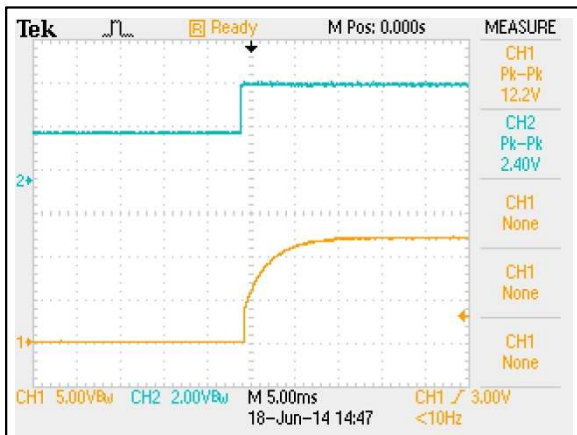

Figure 23: AEE03B18-L Output Voltage Startup Characteristic by On/Off
 Vin = 24Vdc Load: Io = 3.33A
 Ch 1: Vo Ch 2: Remote On/Off

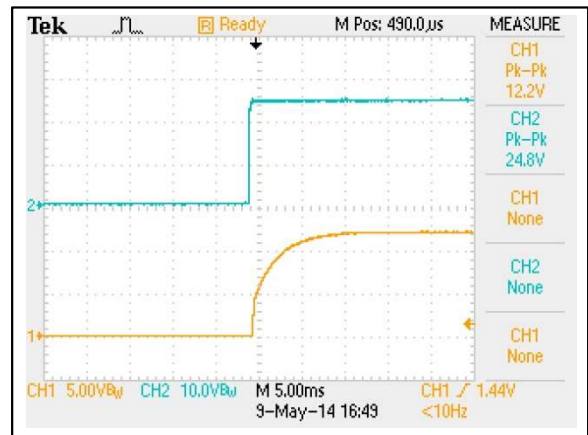

Figure 24: AEE03B18-L Output Voltage Startup Characteristic by Vin
 Vin = 24Vdc Load: Io = 3.33A
 Ch 1: Vo Ch 2: Vin

ELECTRICAL SPECIFICATIONS

AEE03B18-L Performance Curves

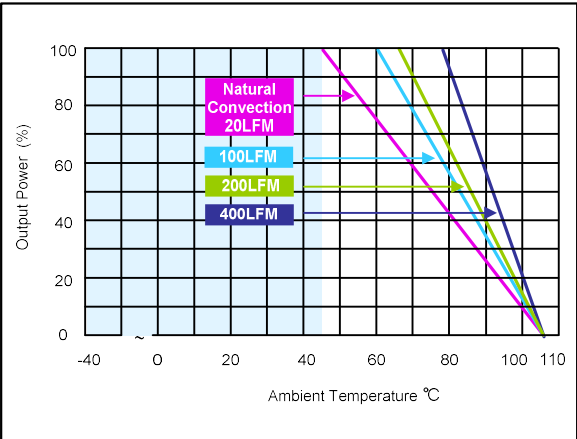

Figure 25: AEE03B18-L Derating Curves (without heatsink)
 Vin = 24Vdc Load: Io = 0 to 3.33A

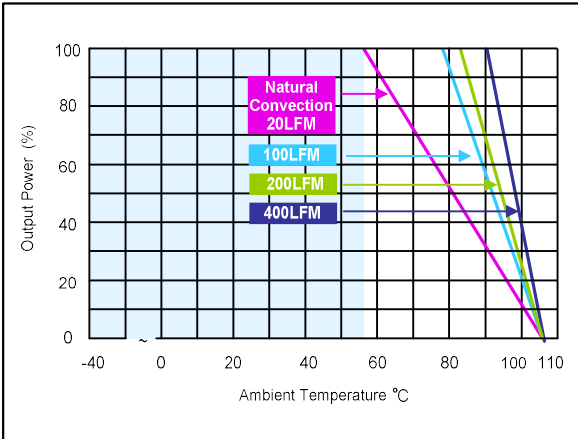

Figure 26: AEE03B18-L Derating Curves (with heatsink)
 Vin = 24Vdc Load: Io = 0 to 3.33A

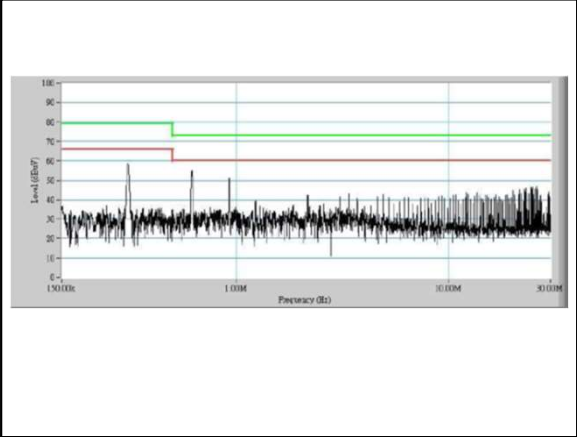

Figure 27: AEE03B18-L Conduction Emission of EN550122 Class A
 Vin = 24Vdc Load: Io = 3.33A

Note - All test conditions are at 25 °C

ELECTRICAL SPECIFICATIONS

AEE02C18-L Performance Curves

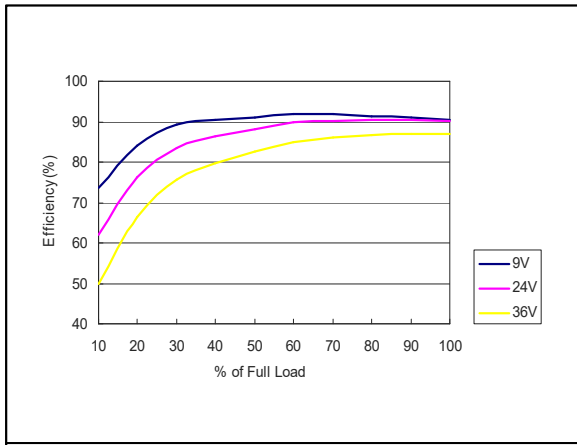

Figure 28: AEE02C18-L Efficiency Versus Output Current Curve
 Vin = 9 to 36Vdc Load: Io = 0 to 2.67A

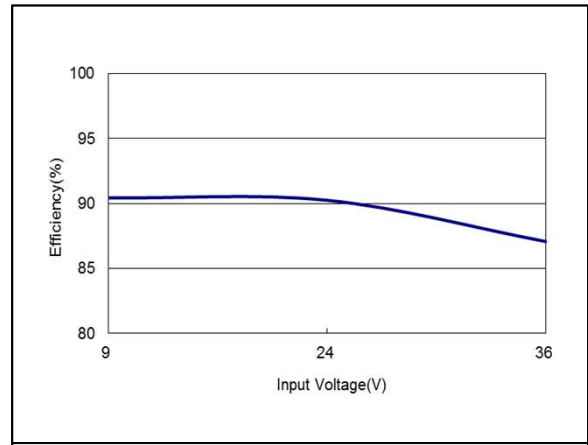

Figure 29: AEE02C18-L Efficiency Versus Input Voltage Curve
 Vin = 9 to 36Vdc Load: Io = 2.67A

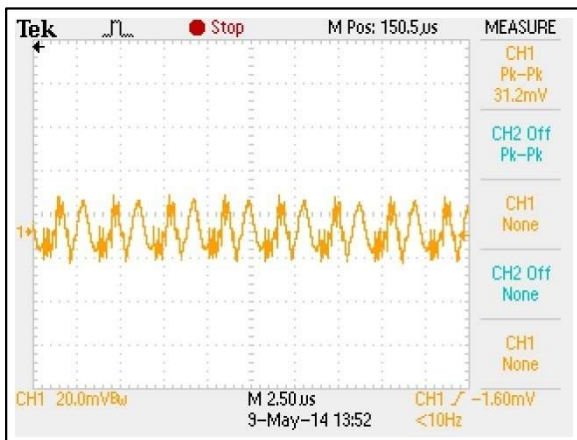

Figure 30: AEE02C18-L Ripple and Noise Measurement
 Vin = 24Vdc Load: Io = 2.67A
 Ch 1: Vo

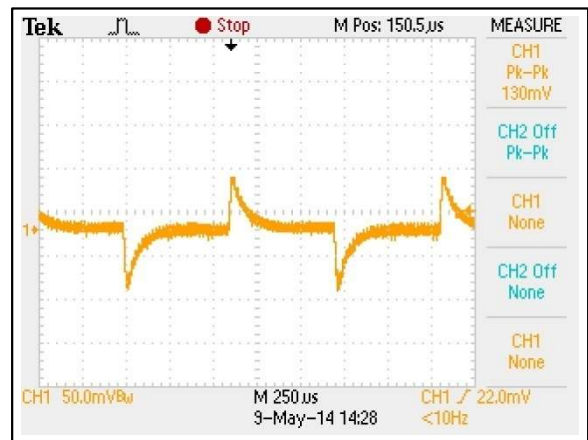

Figure 31: AEE02C18-L Transient Response
 Vin = 24Vdc Load: Io = 100% to 75% load change
 Ch 1: Vo

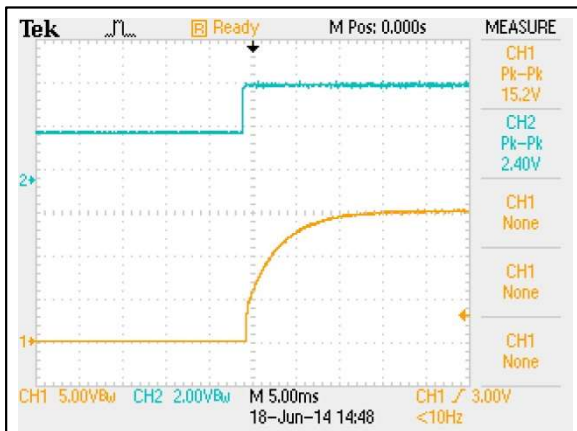

Figure 32: AEE02C18-L Output Voltage Startup Characteristic by On/Off
 Vin = 24Vdc Load: Io = 2.67A
 Ch 1: Vo Ch 2: Remote On/Off

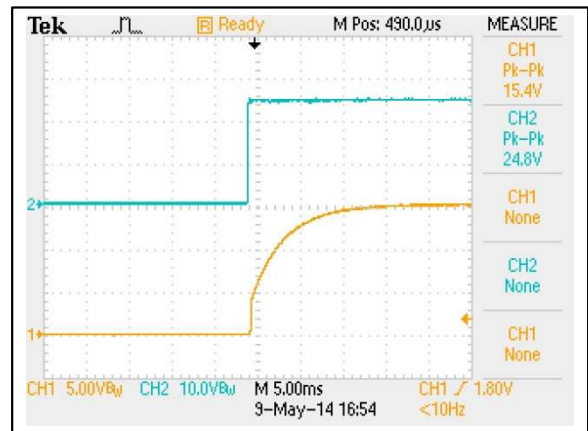

Figure 33: AEE02C18-L Output Voltage Startup Characteristic by Vin
 Vin = 24Vdc Load: Io = 2.67A
 Ch 1: Vo Ch 2: Vin

ELECTRICAL SPECIFICATIONS

AEE02C18-L Performance Curves

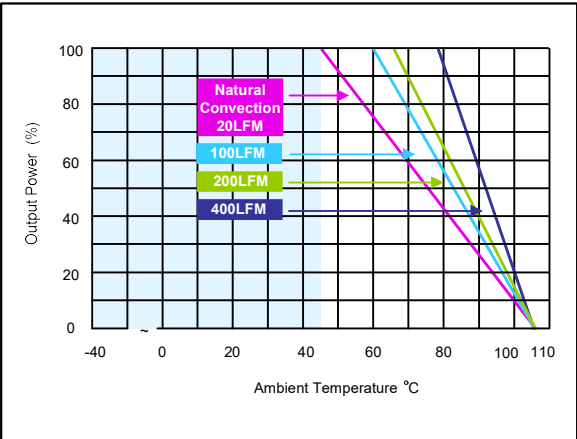

Figure 34: AEE02C18-L Derating Curves (without heatsink)
 Vin = 24Vdc Load: Io = 0 to 2.67A

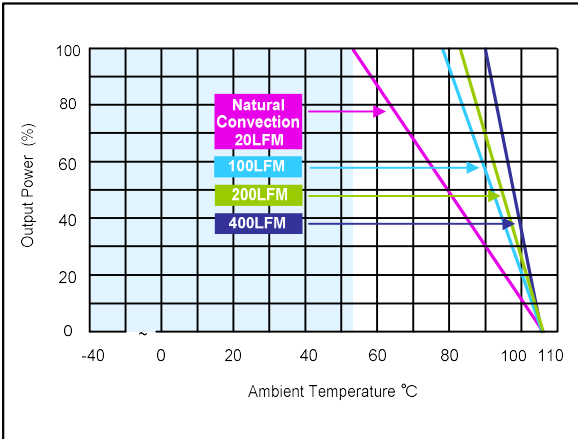

Figure 35: AEE02C18-L Derating Curves (with heatsink)
 Vin = 24Vdc Load: Io = 0 to 2.67A

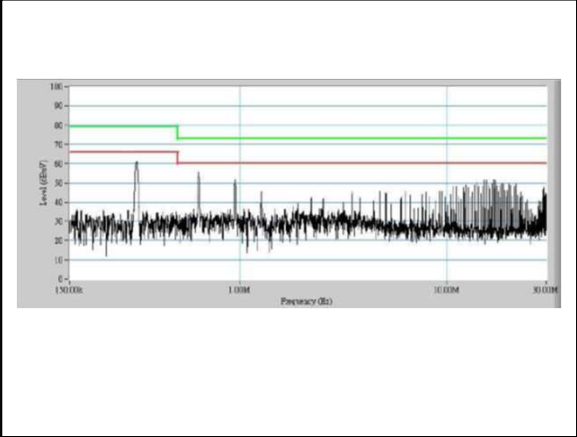

Figure 36: AEE02C18-L Conduction Emission of EN550122 Class A
 Vin = 24Vdc Load: Io = 2.67A

Note - All test conditions are at 25 °C

ELECTRICAL SPECIFICATIONS

AEE01H18-L Performance Curves

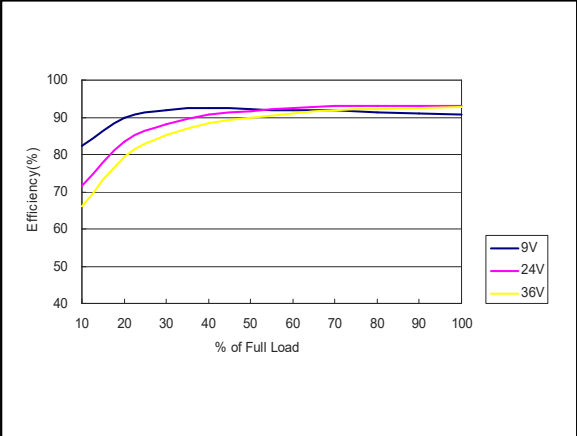

Figure 37: AEE01H18-L Efficiency Versus Output Current Curve
 Vin = 9 to 36Vdc Load: Io = 0 to 1.67A

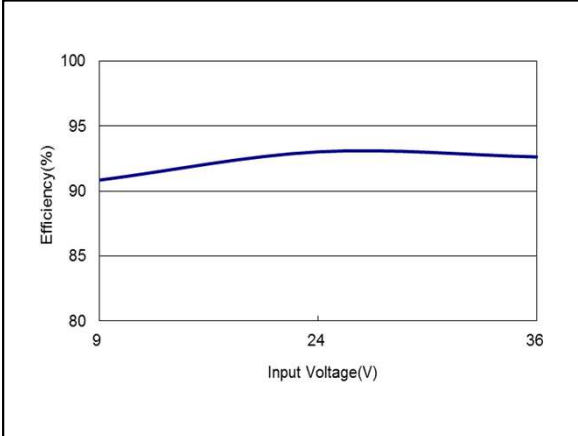

Figure 38: AEE01H18-L Efficiency Versus Input Voltage Curve
 Vin = 9 to 36Vdc Load: Io = 1.67A

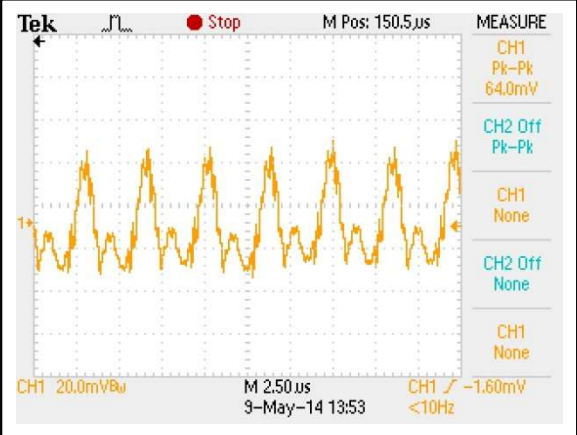

Figure 39: AEE01H18-L Ripple and Noise Measurement
 Vin = 24Vdc Load: Io = 1.67A
 Ch 1: Vo

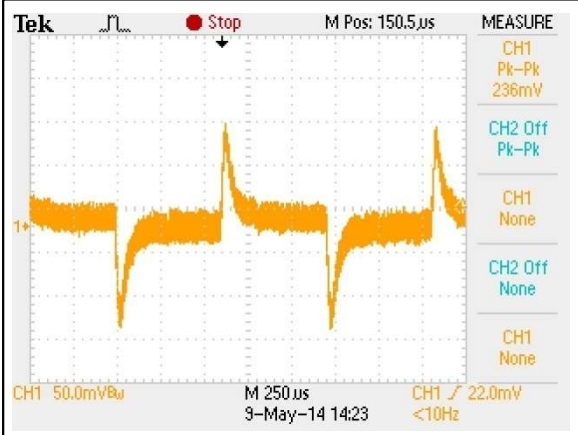

Figure 40: AEE01H18-L Transient Response
 Vin = 24Vdc Load: Io = 100% to 75% load change
 Ch 1: Vo

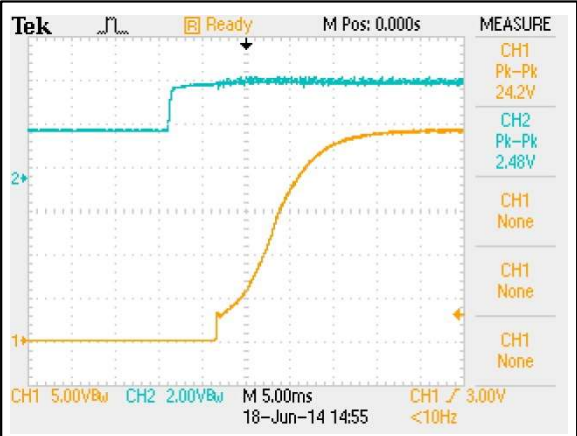

Figure 41: AEE01H18-L Output Voltage Startup Characteristic by On/Off
 Vin = 24Vdc Load: Io = 1.67A
 Ch 1: Vo Ch 2: Remote On/Off

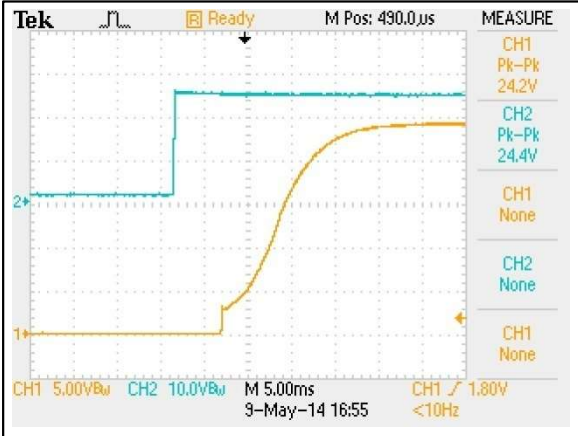

Figure 42: AEE01H18-L Output Voltage Startup Characteristic by Vin
 Vin = 24Vdc Load: Io = 1.67A
 Ch 1: Vo Ch 2: Vin

ELECTRICAL SPECIFICATIONS

AEE01H18-L Performance Curves

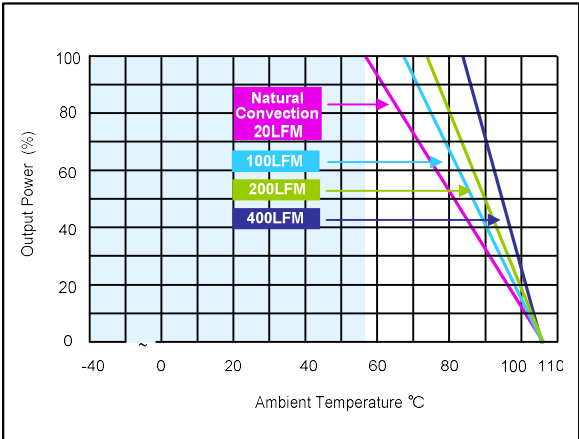

Figure 43: AEE01H18-L Derating Curves (without heatsink)
Vin = 24Vdc Load: Io = 0 to 1.67A

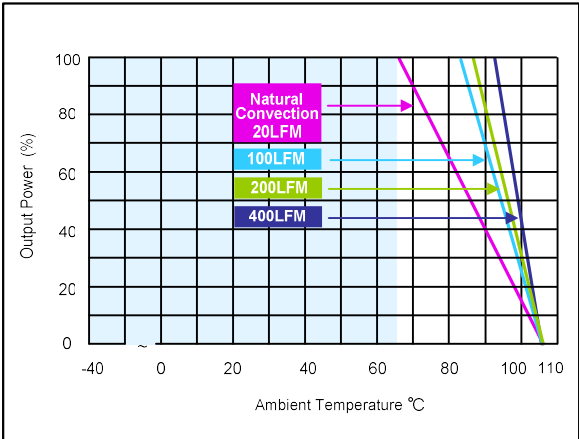

Figure 44: AEE01H18-L Derating Curves (with heatsink)
Vin = 24Vdc Load: Io = 0 to 1.67A

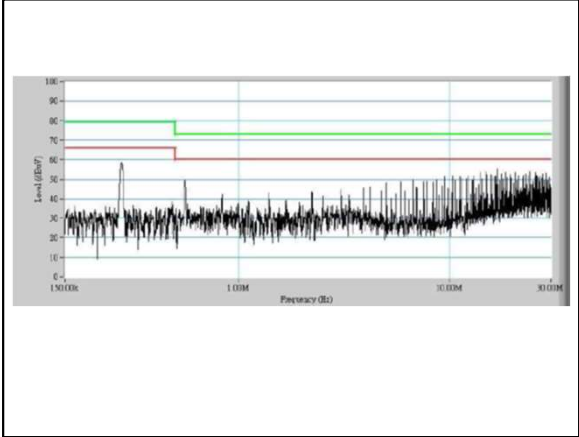

Figure 45: AEE01H18-L Conduction Emission of EN550122 Class A
Vin = 24Vdc Load: Io = 1.67A

Note - All test conditions are at 25 °C

ELECTRICAL SPECIFICATIONS

AEE01BB18-L Performance Curves

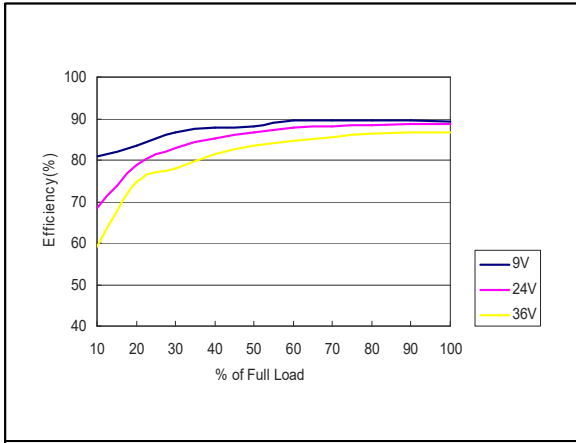

Figure 46: AEE01BB18-L Efficiency Versus Output Current Curve
 Vin = 9 to 36Vdc Load: Io = 0 to ±1.67A

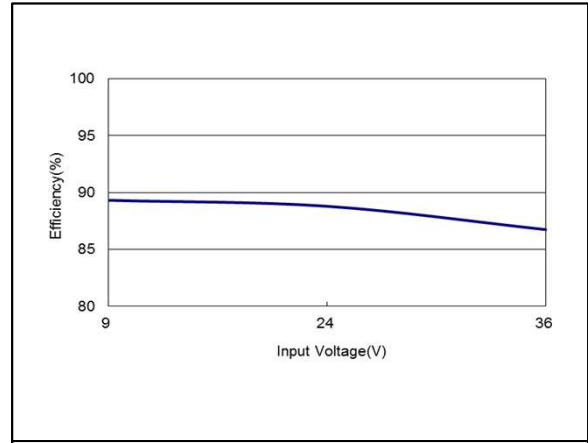

Figure 47: AEE01BB18-L Efficiency Versus Input Voltage Curve
 Vin = 9 to 36Vdc Load: Io = ±1.67A

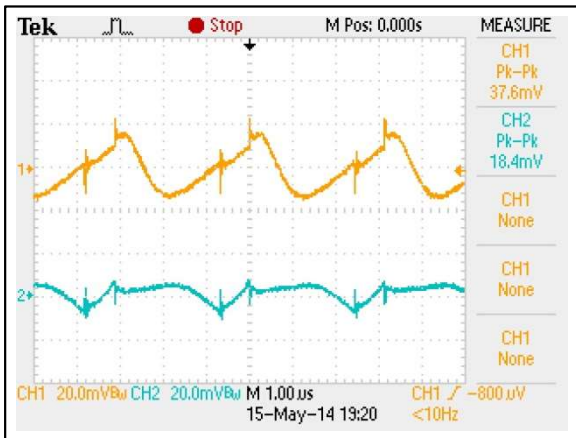

Figure 48: AEE01BB18-L Ripple and Noise Measurement
 Vin = 24Vdc Load: Io = ±1.67A
 Ch 1: Vo1 Ch 1: Vo2

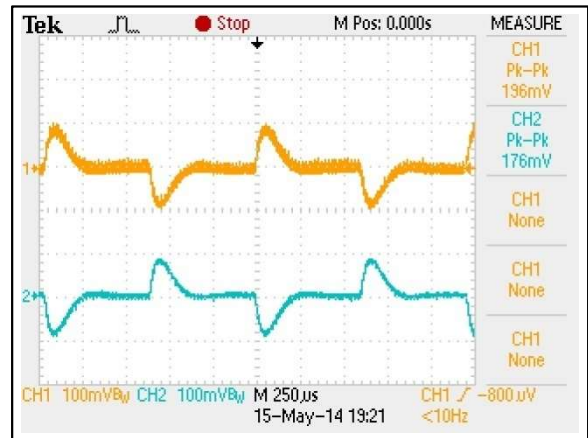

Figure 49: AEE01BB18-L Transient Response
 Vin = 24Vdc Load: Io = 100% to 75% load change
 Ch 1: Vo1 Ch 1: Vo2

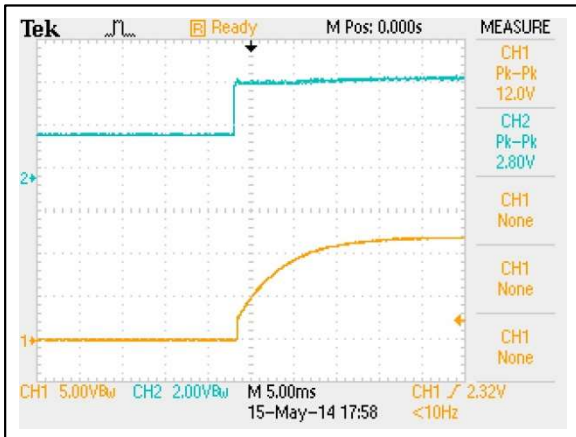

Figure 50: AEE01BB18-L Output Voltage Startup Characteristic by On/Off
 Vin = 24Vdc Load: Io = ±1.67A
 Ch 1: Vo Ch 2: Remote On/Off

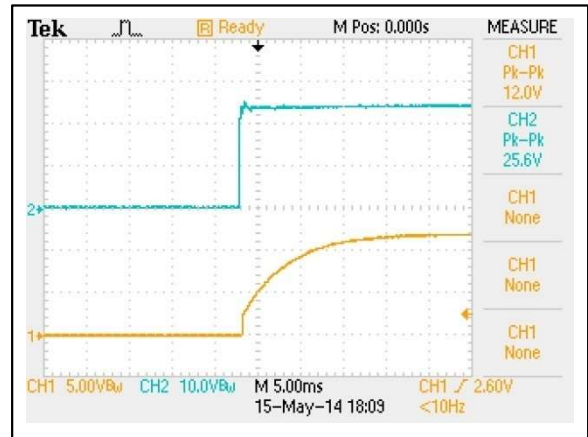

Figure 51: AEE01BB18-L Output Voltage Startup Characteristic by Vin
 Vin = 24Vdc Load: Io = ±1.67A
 Ch 1: Vo Ch 2: Vin

ELECTRICAL SPECIFICATIONS

AEE01BB18-L Performance Curves

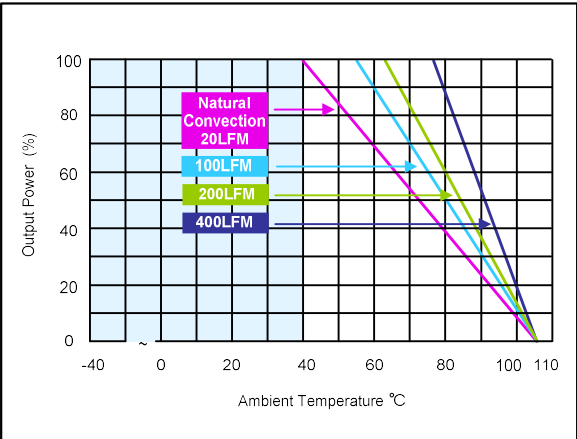

Figure 52: AEE01BB18-L Derating Curves (without heatsink)
 Vin = 24Vdc Load: Io = 0 to ±1.67A

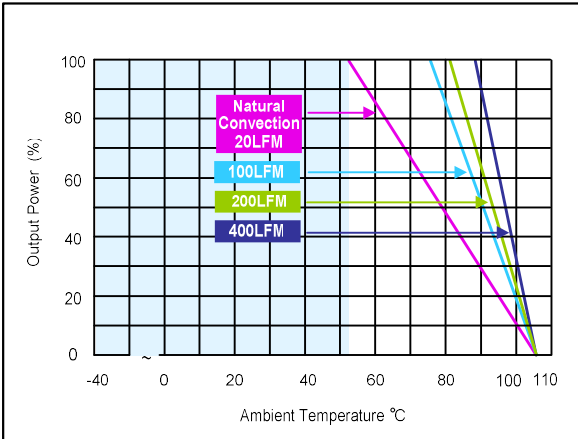

Figure 53: AEE01BB18-L Derating Curves (with heatsink)
 Vin = 24Vdc Load: Io = 0 to ±1.67A

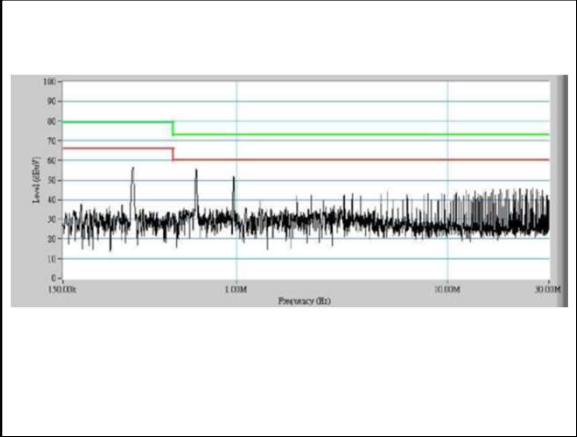

Figure 54: AEE01BB18-L Conduction Emission of EN550122 Class A
 Vin = 24Vdc Load: Io = ±1.67A

Note - All test conditions are at 25 °C

ELECTRICAL SPECIFICATIONS

AEE01CC18-L Performance Curves

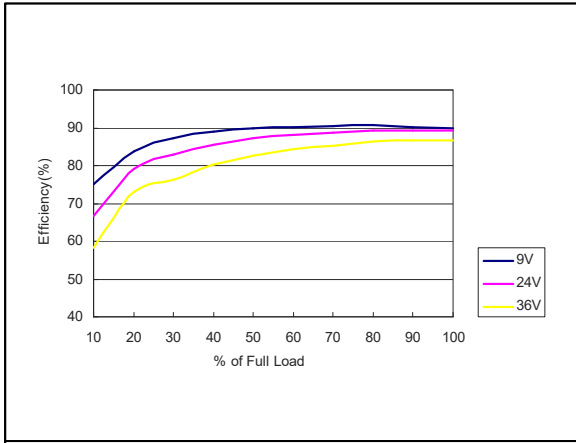

Figure 55: AEE01CC18-L Efficiency Versus Output Current Curve
 Vin = 18 to 75Vdc Load: Io = 0 to ±1.33A

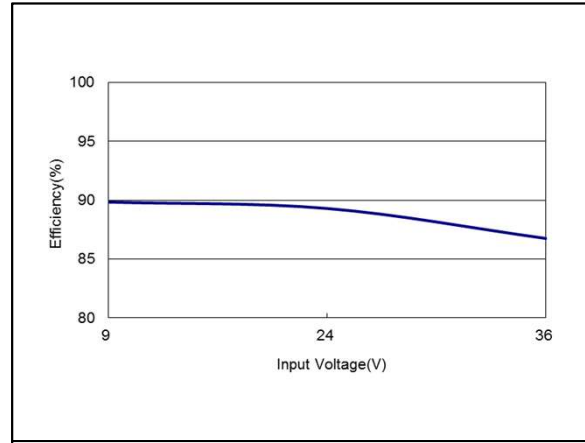

Figure 56: AEE01CC18-L Efficiency Versus Input Voltage Curve
 Vin = 18 to 75Vdc Load: Io = ±1.33A

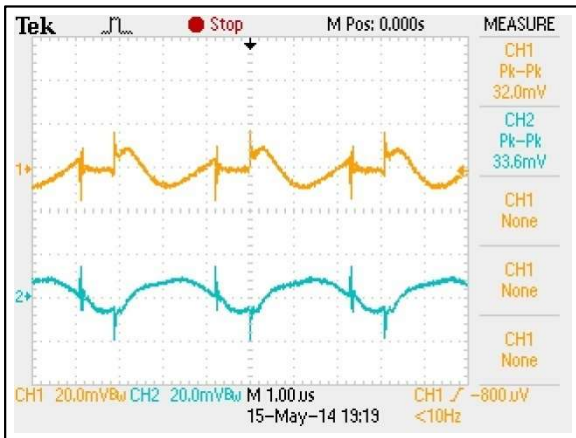

Figure 57: AEE01CC18-L Ripple and Noise Measurement
 Vin = 48Vdc Load: Io = ±1.33A
 Ch 1: Vo1 Ch 1: Vo2

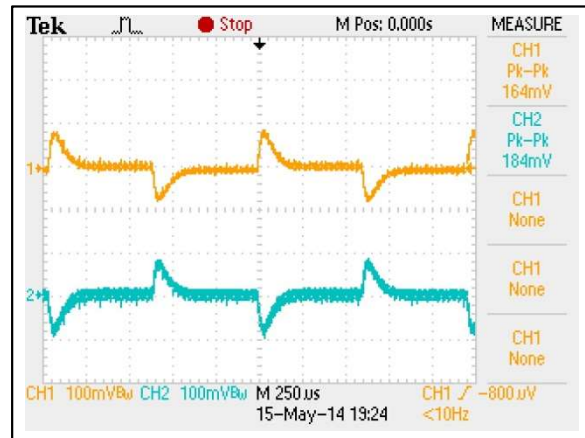

Figure 58: AEE01CC18-L Transient Response
 Vin = 48Vdc Load: Io = 100% to 75% load change
 Ch 1: Vo1 Ch 1: Vo2

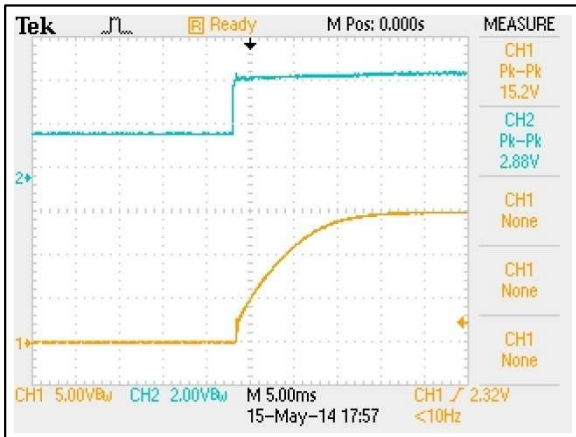

Figure 59: AEE01CC18-L Output Voltage Startup Characteristic by On/Off
 Vin = 48Vdc Load: Io = ±1.33A
 Ch 1: Vo Ch 2: Remote On/Off

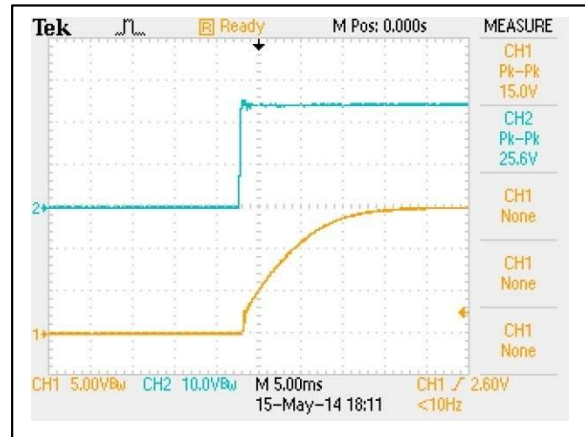

Figure 60: AEE01CC18-L Output Voltage Startup Characteristic by Vin
 Vin = 48Vdc Load: Io = ±1.33A
 Ch 1: Vo Ch 2: Vin

ELECTRICAL SPECIFICATIONS

AEE01CC18-L Performance Curves

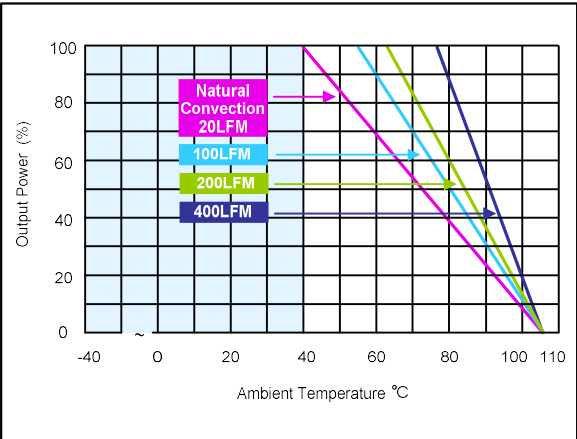

Figure 61: AEE01CC18-L Derating Curves (without heatsink)
 Vin = 48Vdc Load: Io = 0 to ±1.33A

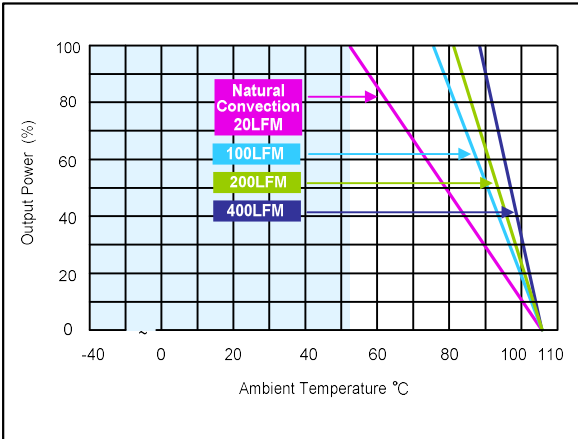

Figure 62: AEE01CC18-L Derating Curves (with heatsink)
 Vin = 48Vdc Load: Io = 0 to ±1.33A

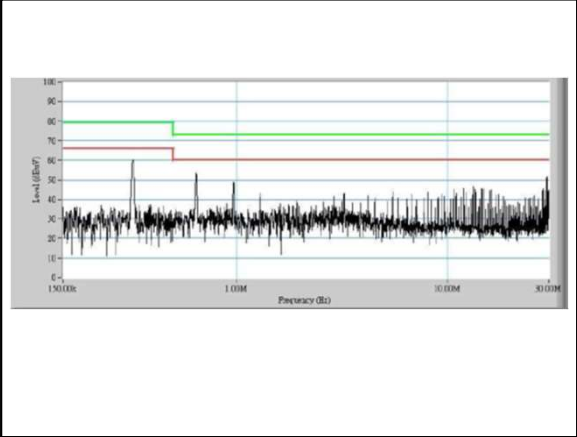

Figure 63: AEE01CC18-L Conduction Emission of EN550122 Class A
 Vin = 48Vdc Load: Io = ±1.33A

Note - All test conditions are at 25 °C

ELECTRICAL SPECIFICATIONS

AEE08F36-L Performance Curves

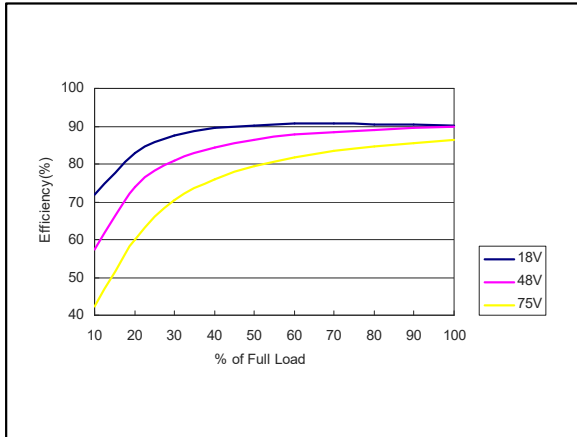

Figure 64: AEE08F36-L Efficiency Versus Output Current Curve
 Vin = 18 to 75Vdc Load: Io = 0 to 8A

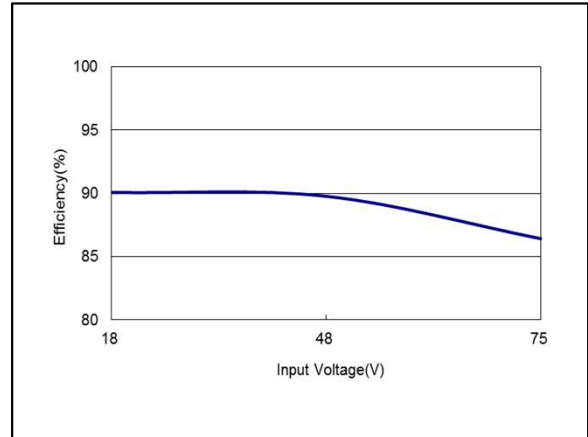

Figure 65: AEE08F36-L Efficiency Versus Input Voltage Curve
 Vin = 18 to 75Vdc Load: Io = 8A

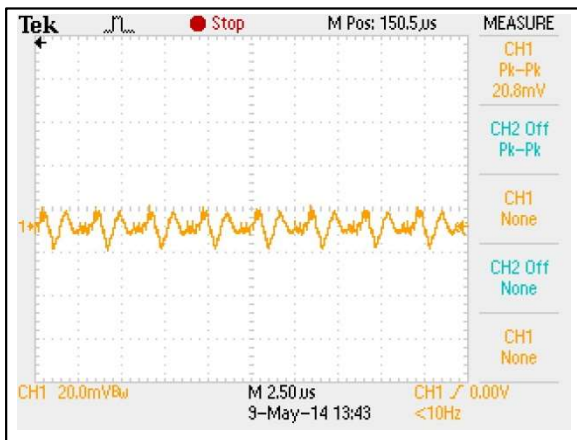

Figure 66: AEE08F36-L Ripple and Noise Measurement
 Vin = 48Vdc Load: Io = 8A
 Ch 1: Vo

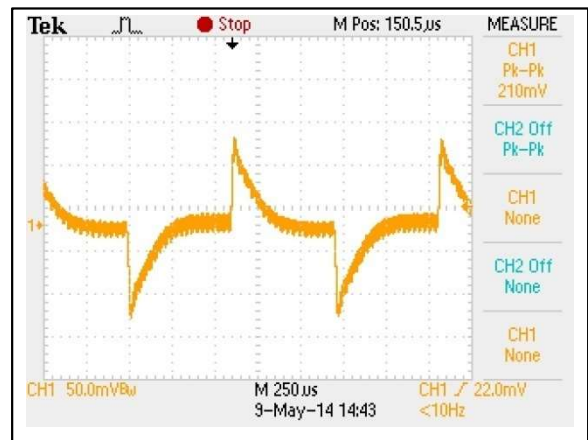

Figure 67: AEE08F36-L Transient Response
 Vin = 48Vdc Load: Io = 100% to 75% load change
 Ch 1: Vo

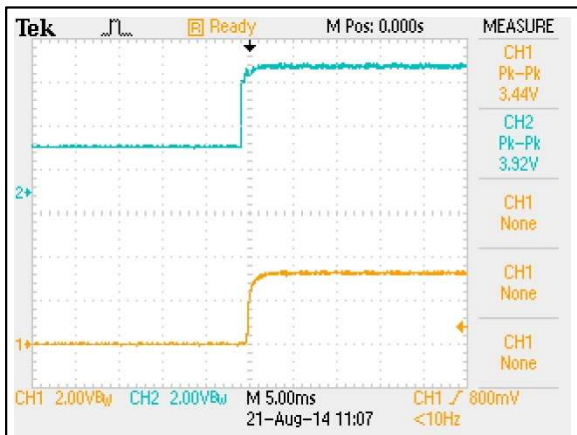

Figure 68: AEE08F36-L Output Voltage Startup Characteristic by On/Off
 Vin = 48Vdc Load: Io = 8A
 Ch 1: Vo Ch 2: Remote On/Off

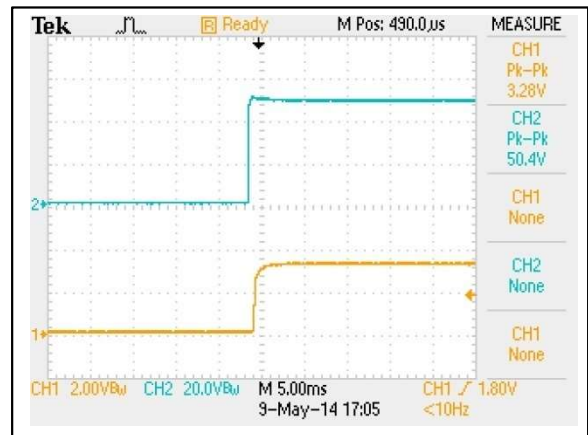

Figure 69: AEE08F36-L Output Voltage Startup Characteristic by Vin
 Vin = 48Vdc Load: Io = 8A
 Ch 1: Vo Ch 2: Vin

ELECTRICAL SPECIFICATIONS

AEE08F36-L Performance Curves

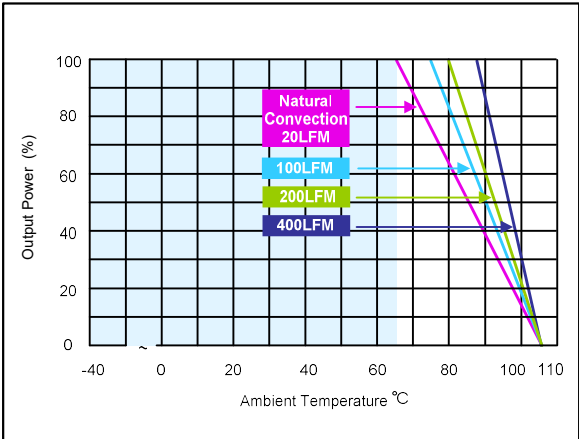

Figure 70: AEE08F36-L Derating Curves (without heatsink)
Vin = 48Vdc Load: Io = 0 to 8A

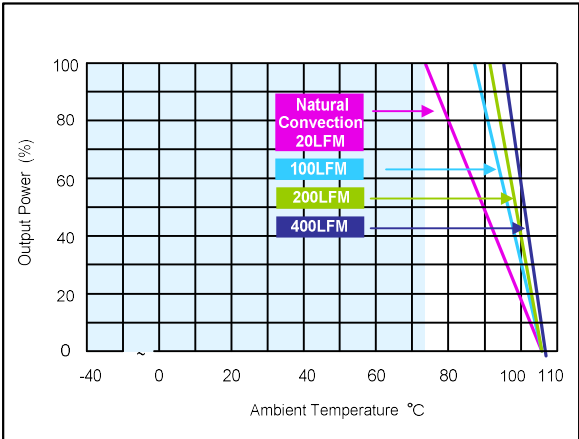

Figure 71: AEE08F36-L Derating Curves (with heatsink)
Vin = 48Vdc Load: Io = 0 to 8A

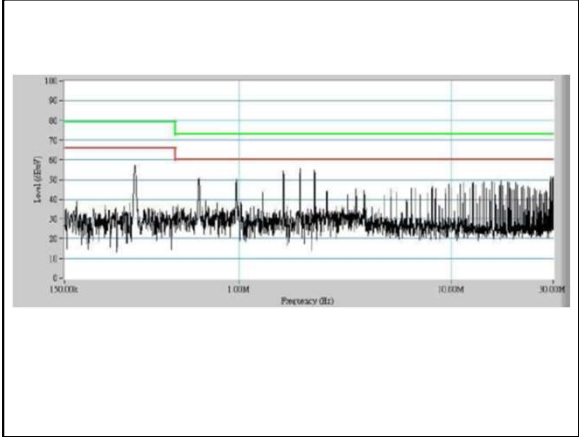

Figure 72: AEE08F36-L Conduction Emission of EN550122 Class A
Vin = 48Vdc Load: Io = 8A

Note - All test conditions are at 25 °C

ELECTRICAL SPECIFICATIONS

AEE08A36-L Performance Curves

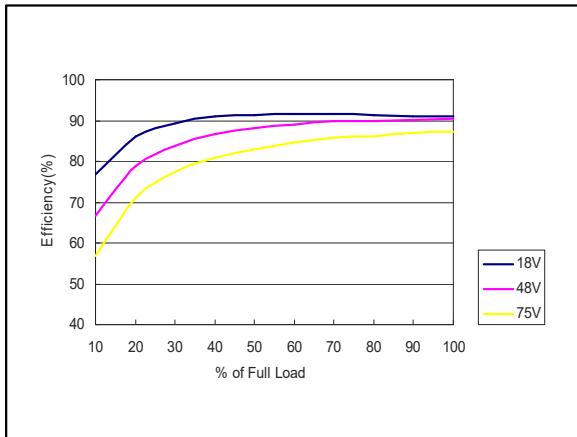

Figure 73: AEE08A36-L Efficiency Versus Output Current Curve
 Vin = 18 to 75Vdc Load: Io = 0 to 8A

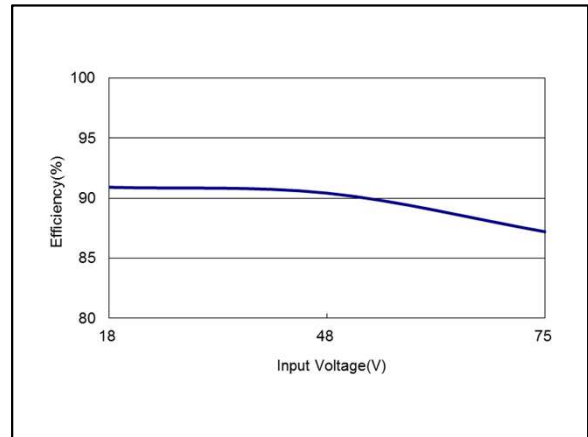

Figure 74: AEE08A36-L Efficiency Versus Input Voltage Curve
 Vin = 18 to 75Vdc Load: Io = 8A

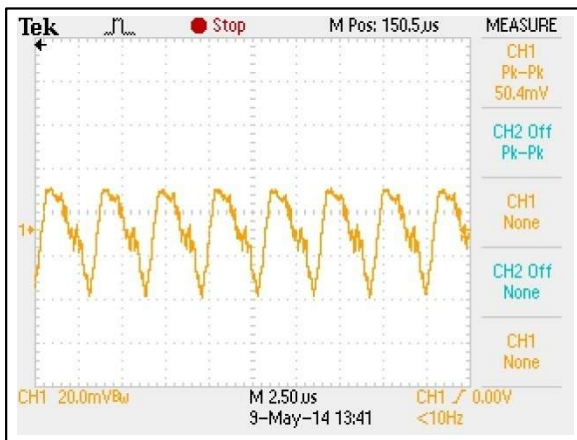

Figure 75: AEE08A36-L Ripple and Noise Measurement
 Vin = 48Vdc Load: Io = 8A
 Ch 1: Vo

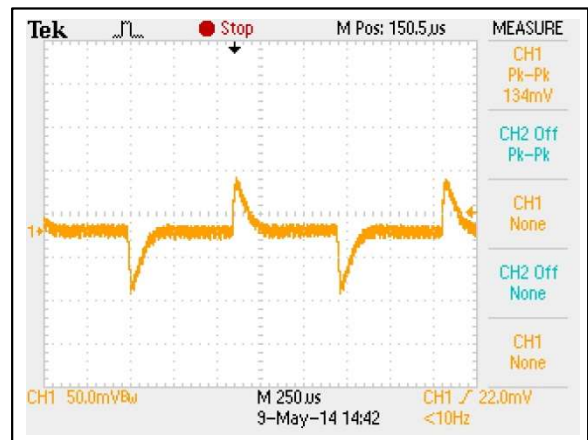

Figure 76: AEE08A36-L Transient Response
 Vin = 48Vdc Load: Io = 100% to 75% load change
 Ch 1: Vo

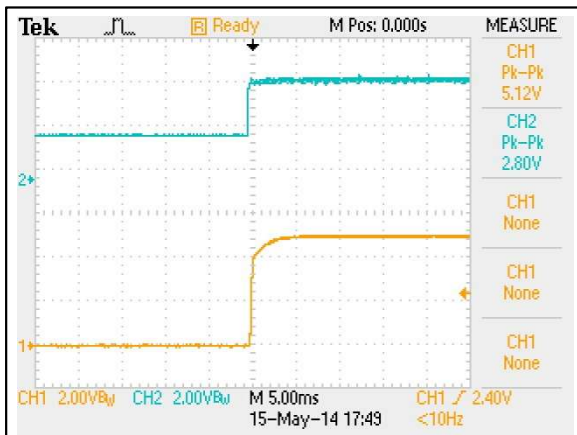

Figure 77: AEE08A36-L Output Voltage Startup Characteristic by On/Off
 Vin = 48Vdc Load: Io = 8A
 Ch 1: Vo Ch 2: Remote On/Off

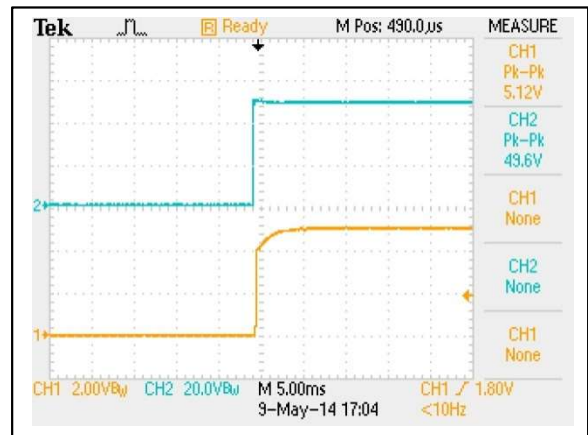

Figure 78: AEE08A36-L Output Voltage Startup Characteristic by Vin
 Vin = 48Vdc Load: Io = 8A
 Ch 1: Vo Ch 2: Vin

ELECTRICAL SPECIFICATIONS

AEE08A36-L Performance Curves

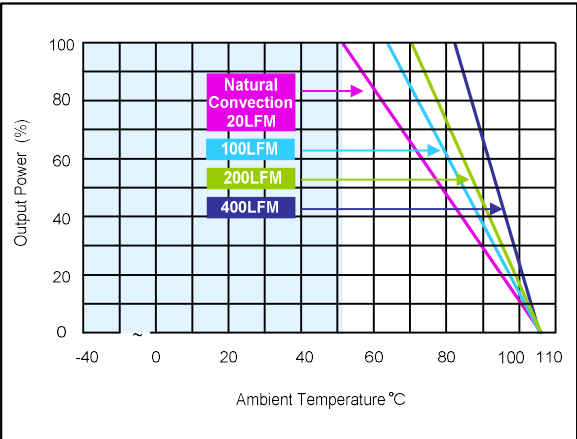

Figure 79: AEE08A36-L Derating Curves (without heatsink)
 Vin = 48Vdc Load: Io = 0 to 8A

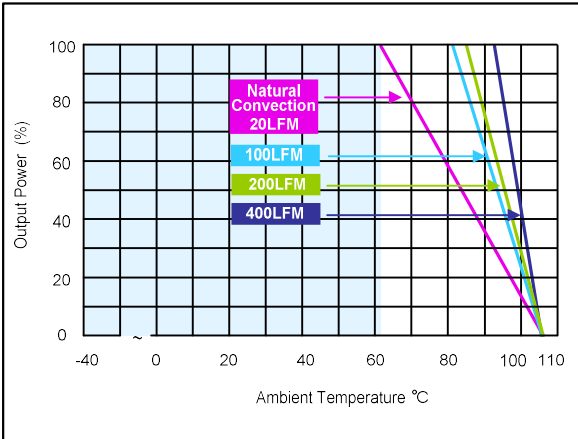

Figure 80: AEE08A36-L Derating Curves (with heatsink)
 Vin = 48Vdc Load: Io = 0 to 8A

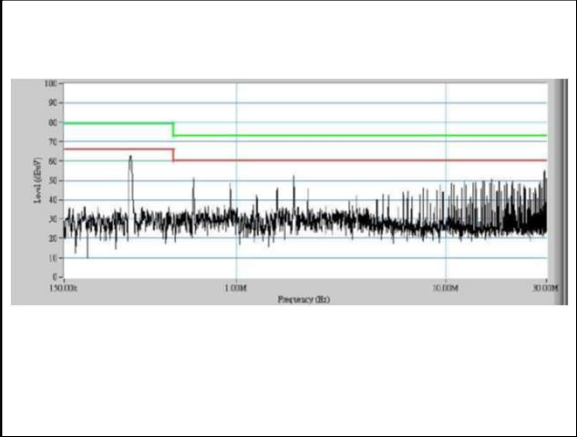

Figure 81: AEE08A36-L Conduction Emission of EN550122 Class A
 Vin = 48Vdc Load: Io = 8A

Note - All test conditions are at 25 °C

ELECTRICAL SPECIFICATIONS

AEE03B36-L Performance Curves

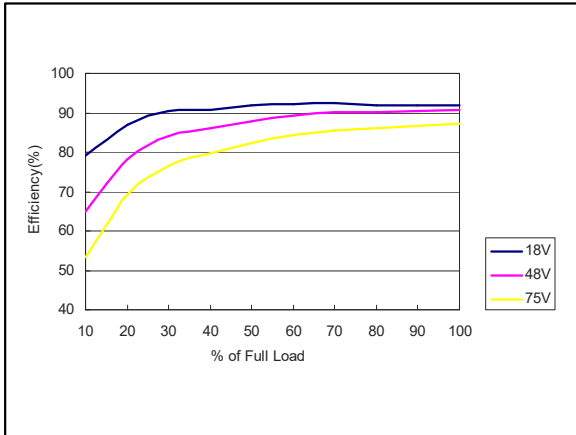

Figure 82: AEE03B36-L Efficiency Versus Output Current Curve
 Vin = 18 to 75Vdc Load: Io = 0 to 3.33A

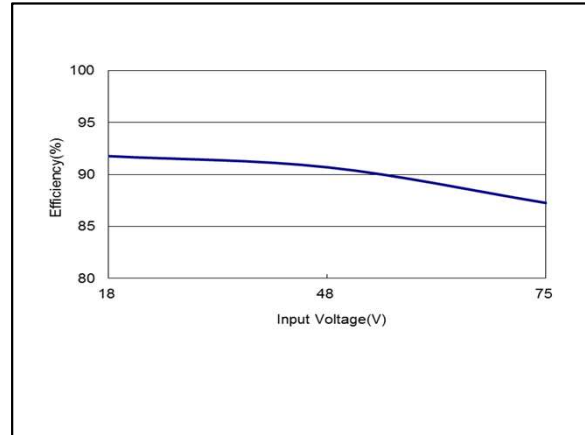

Figure 83: AEE03B36-L Efficiency Versus Input Voltage Curve
 Vin = 18 to 75Vdc Load: Io = 3.33A

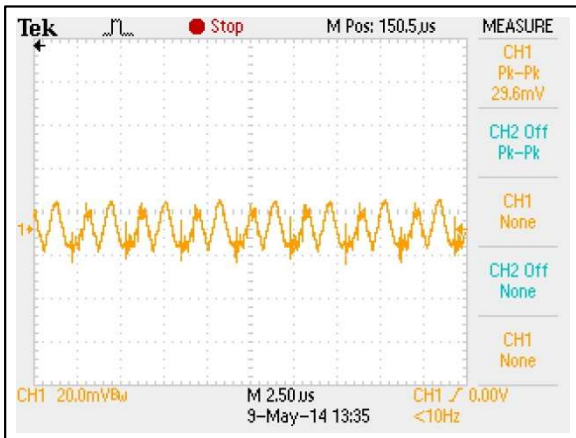

Figure 84: AEE03B36-L Ripple and Noise Measurement
 Vin = 48Vdc Load: Io = 3.33A
 Ch 1: Vo

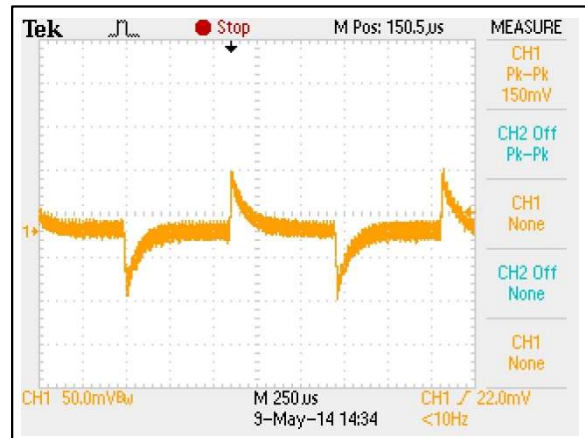

Figure 85: AEE03B36-L Transient Response
 Vin = 48Vdc Load: Io = 100% to 75% load change
 Ch 1: Vo

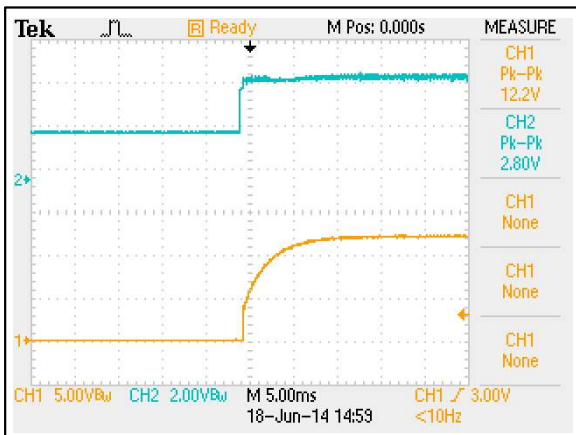

Figure 86: AEE03B36-L Output Voltage Startup Characteristic by On/Off
 Vin = 48Vdc Load: Io = 3.33A
 Ch 1: Vo Ch 2: Remote On/Off



Figure 87: AEE03B36-L Output Voltage Startup Characteristic by Vin
 Vin = 48Vdc Load: Io = 3.33A
 Ch 1: Vo Ch 2: Vin

ELECTRICAL SPECIFICATIONS

AEE03B36-L Performance Curves

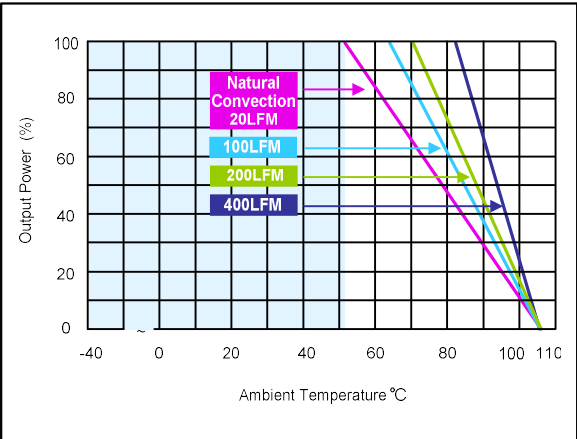

Figure 88: AEE03B36-L Derating Curves (without heatsink)
Vin = 48Vdc Load: Io = 0 to 3.33A

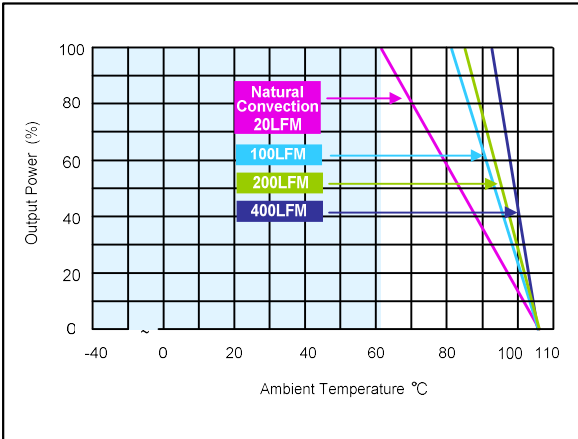

Figure 89: AEE03B36-L Derating Curves (with heatsink)
Vin = 48Vdc Load: Io = 0 to 3.33A

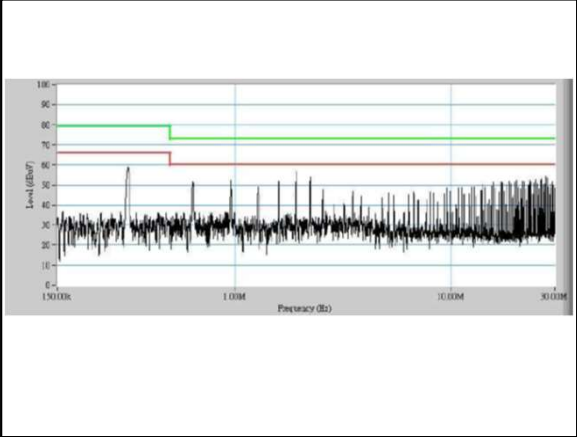

Figure 90: AEE03B36-L Conduction Emission of EN550122 Class A
Vin = 48Vdc Load: Io = 3.33A

Note - All test conditions are at 25 °C

ELECTRICAL SPECIFICATIONS

AEE02C36-L Performance Curves

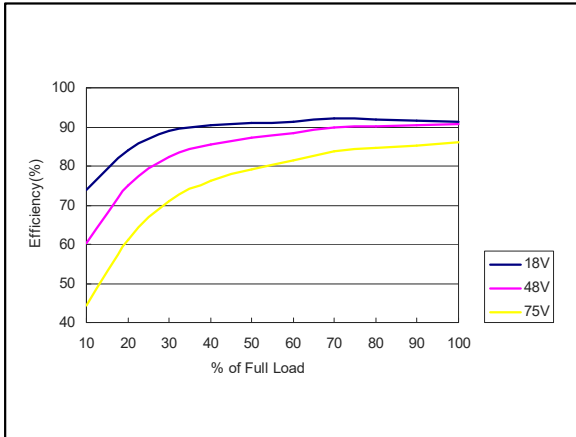

Figure 91: AEE02C36-L Efficiency Versus Output Current Curve
 Vin = 18 to 75Vdc Load: Io = 0 to 2.67A

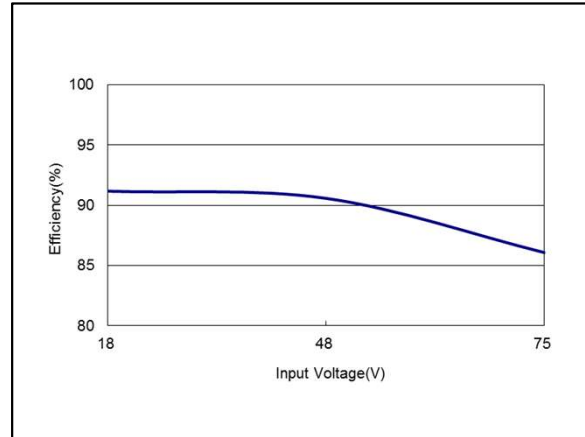

Figure 92: AEE02C36-L Efficiency Versus Input Voltage Curve
 Vin = 18 to 75Vdc Load: Io = 2.67A

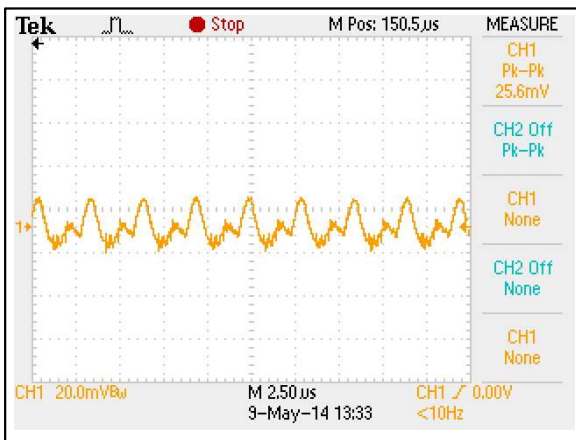

Figure 93: AEE02C36-L Ripple and Noise Measurement
 Vin = 48Vdc Load: Io = 2.67A
 Ch 1: Vo

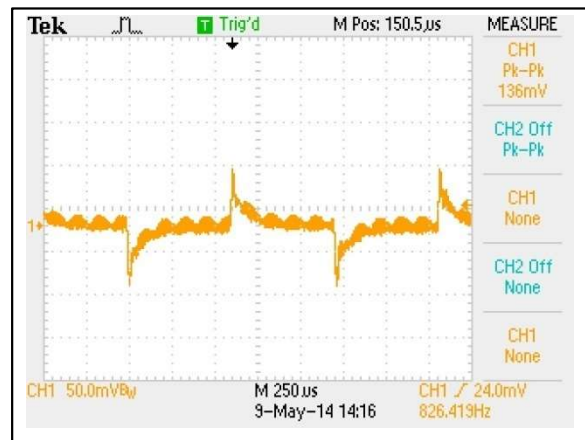

Figure 94: AEE02C36-L Transient Response
 Vin = 48Vdc Load: Io = 100% to 75% load change
 Ch 1: Vo

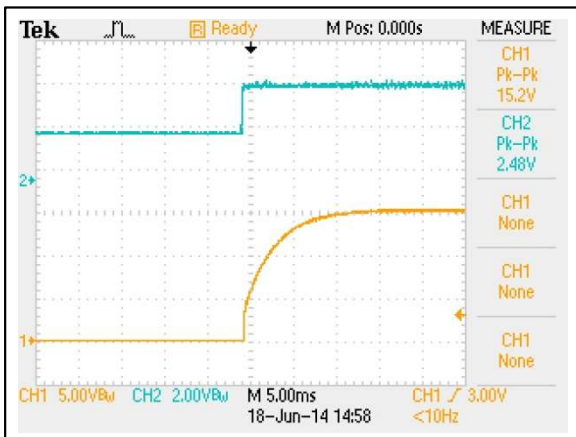

Figure 95: AEE02C36-L Output Voltage Startup Characteristic by On/Off
 Vin = 48Vdc Load: Io = 2.67A
 Ch 1: Vo Ch 2: Remote On/Off

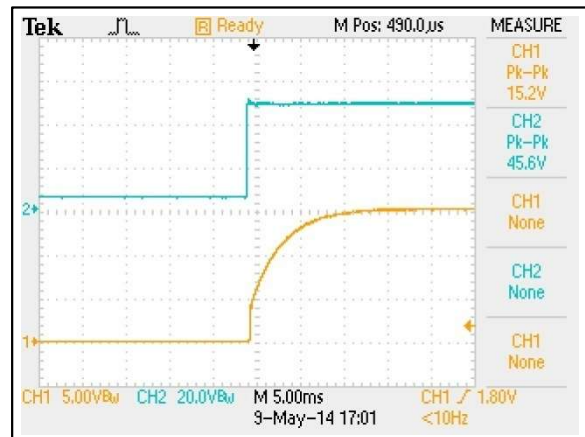

Figure 96: AEE02C36-L Output Voltage Startup Characteristic by Vin
 Vin = 48Vdc Load: Io = 2.67A
 Ch 1: Vo Ch 2: Vin

ELECTRICAL SPECIFICATIONS

AEE02C36-L Performance Curves

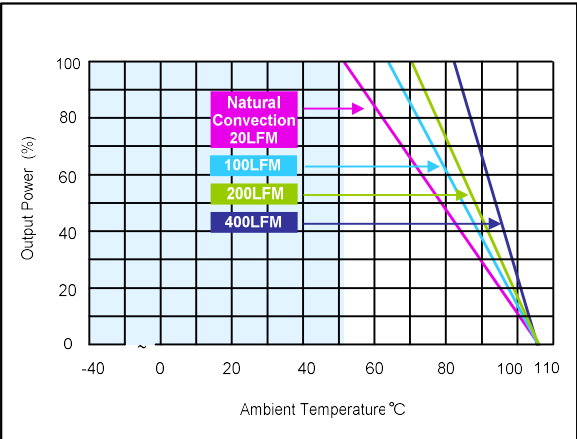

Figure 97: AEE02C36-L Derating Curves (without heatsink)
 Vin = 48Vdc Load: Io = 0 to 2.67A

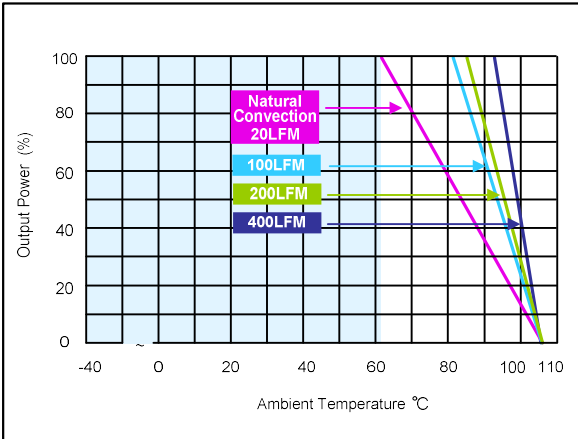

Figure 98: AEE02C36-L Derating Curves (with heatsink)
 Vin = 48Vdc Load: Io = 0 to 2.67A

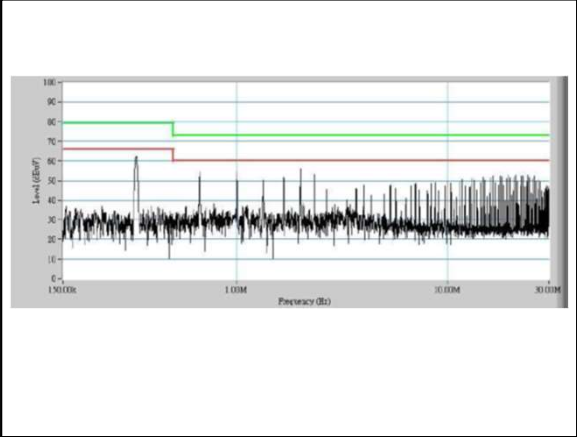

Figure 99: AEE02C36-L Conduction Emission of EN550122 Class A
 Vin = 48Vdc Load: Io = 2.67A

Note - All test conditions are at 25 °C

ELECTRICAL SPECIFICATIONS

AEE01H36-L Performance Curves

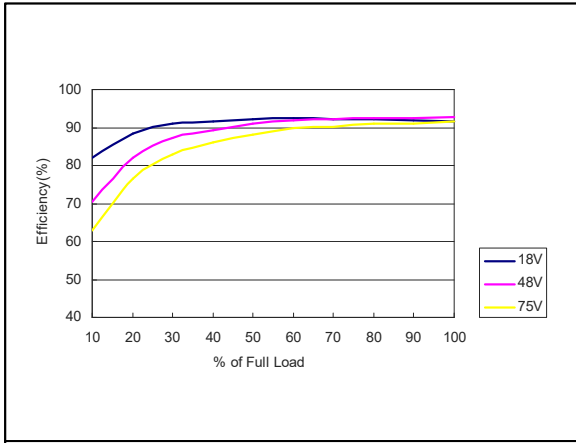

Figure 100: AEE01H36-L Efficiency Versus Output Current Curve
 Vin = 18 to 75Vdc Load: Io = 0 to 1.67A

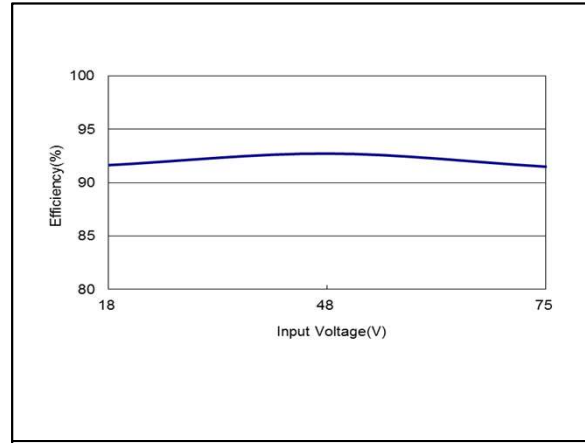

Figure 101: AEE01H36-L Efficiency Versus Input Voltage Curve
 Vin = 18 to 75Vdc Load: Io = 1.67A

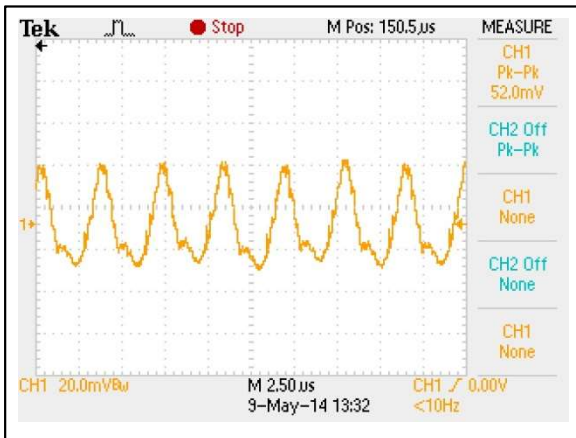

Figure 102: AEE01H36-L Ripple and Noise Measurement
 Vin = 48Vdc Load: Io = 1.67A
 Ch 1: Vo

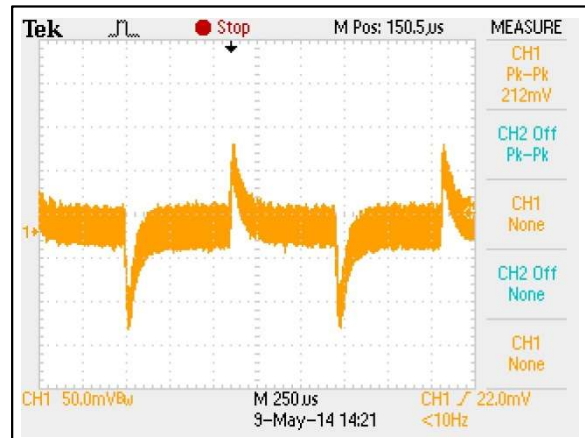

Figure 103: AEE01H36-L Transient Response
 Vin = 48Vdc Load: Io = 100% to 75% load change
 Ch 1: Vo

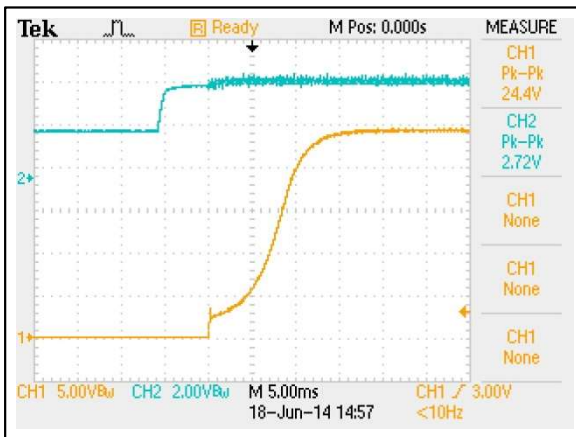

Figure 104: AEE01H36-L Output Voltage Startup Characteristic by On/Off
 Vin = 48Vdc Load: Io = 1.67A
 Ch 1: Vo Ch 2: Remote On/Off

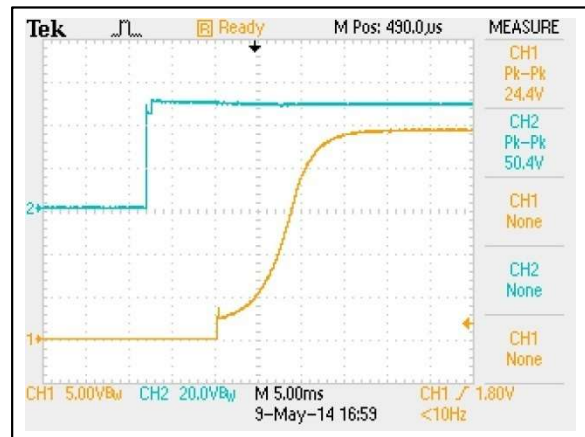

Figure 105: AEE01H36-L Output Voltage Startup Characteristic by Vin
 Vin = 48Vdc Load: Io = 1.67A
 Ch 1: Vo Ch 2: Vin

ELECTRICAL SPECIFICATIONS

AEE01H36-L Performance Curves

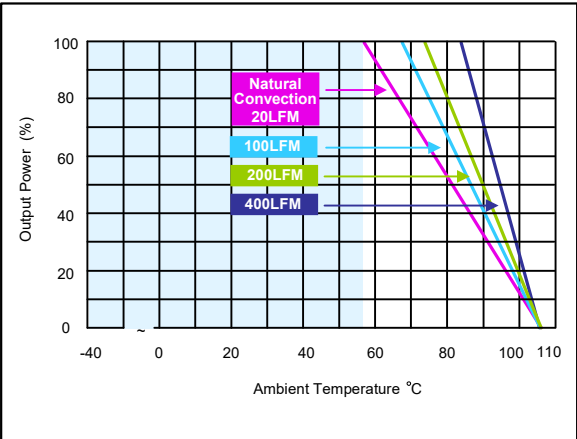

Figure 106: AEE01H36-L Derating Curves (without heatsink)
 Vin = 48Vdc Load: Io = 0 to 1.67A

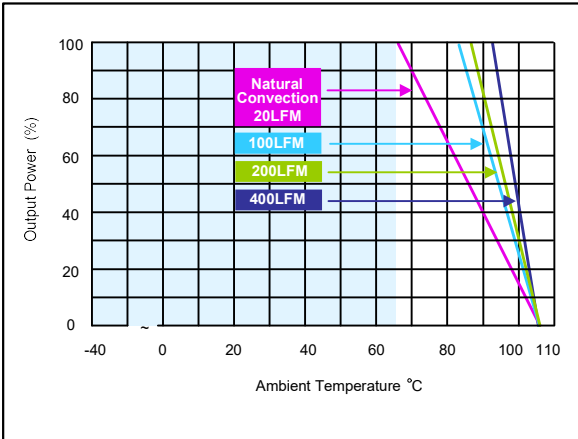

Figure 107: AEE01H36-L Derating Curves (with heatsink)
 Vin = 48Vdc Load: Io = 0 to 1.67A

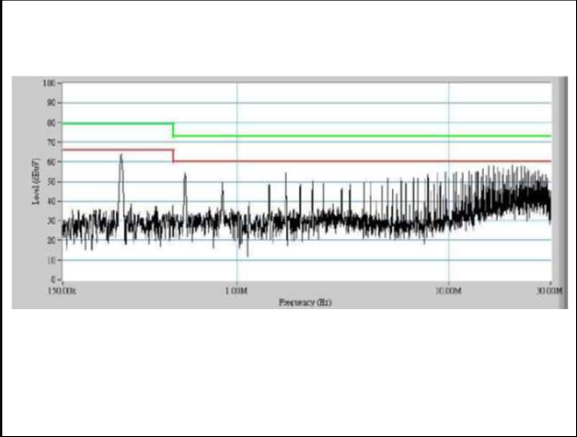

Figure 108: AEE01H36-L Conduction Emission of EN550122 Class A
 Vin = 48Vdc Load: Io = 1.67A

Note - All test conditions are at 25 °C

ELECTRICAL SPECIFICATIONS

AEE01BB36-L Performance Curves

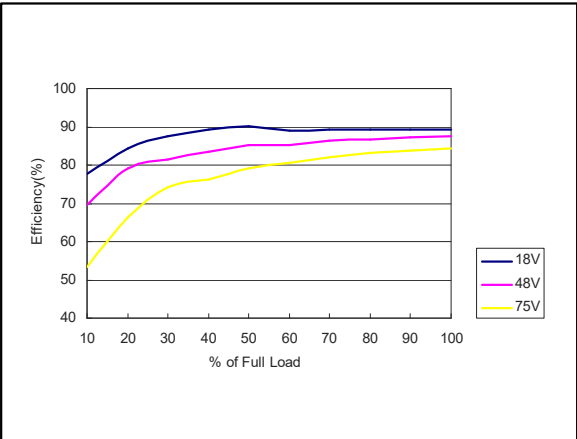

Figure 109: AEE01BB36-L Efficiency Versus Output Current Curve
 Vin = 18 to 75Vdc Load: Io = 0 to ±1.67A

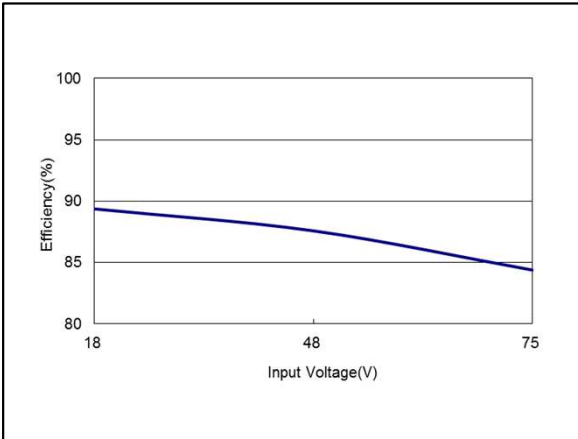

Figure 110: AEE01BB36-L Efficiency Versus Input Voltage Curve
 Vin = 18 to 75Vdc Load: Io = ±1.67A

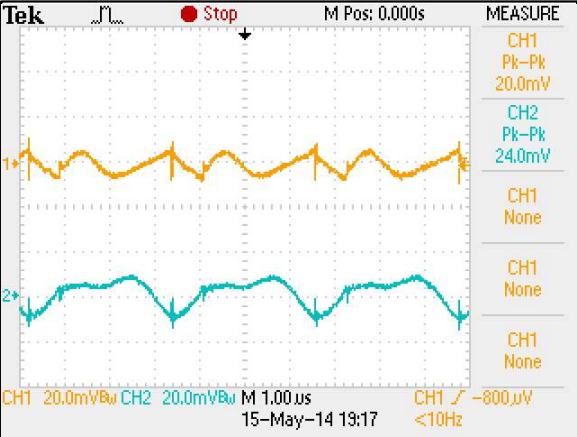

Figure 111: AEE01BB36-L Ripple and Noise Measurement
 Vin = 48Vdc Load: Io = ±1.67A
 Ch 1: Vo1 Ch 2: Vo2

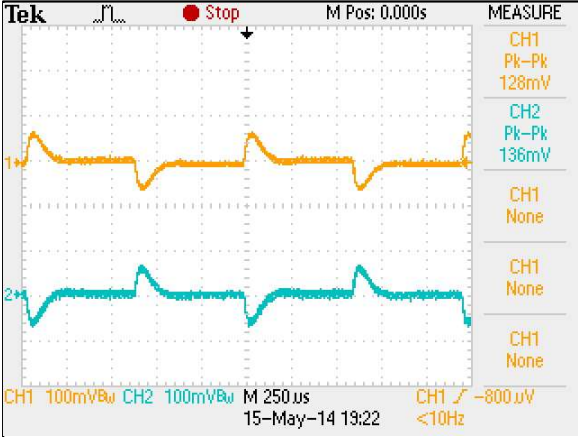

Figure 112: AEE01BB36-L Transient Response
 Vin = 48Vdc Load: Io = 100% to 75% load change
 Ch 1: Vo1 Ch 2: Vo2

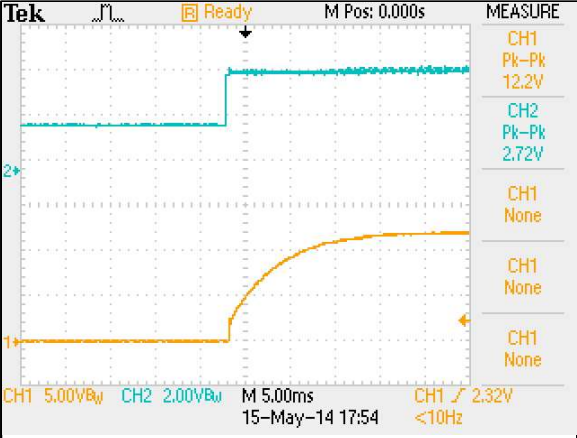

Figure 113: AEE01BB36-L Output Voltage Startup Characteristic by On/Off
 Vin = 48Vdc Load: Io = ±1.67A
 Ch 1: Vo Ch 2: Remote On/Off

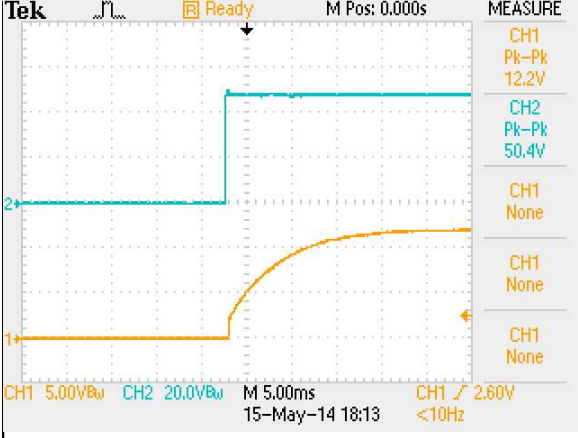

Figure 114: AEE01BB36-L Output Voltage Startup Characteristic by Vin
 Vin = 48Vdc Load: Io = ±1.67A
 Ch 1: Vo Ch 2: Vin

ELECTRICAL SPECIFICATIONS

AEE01BB36-L Performance Curves

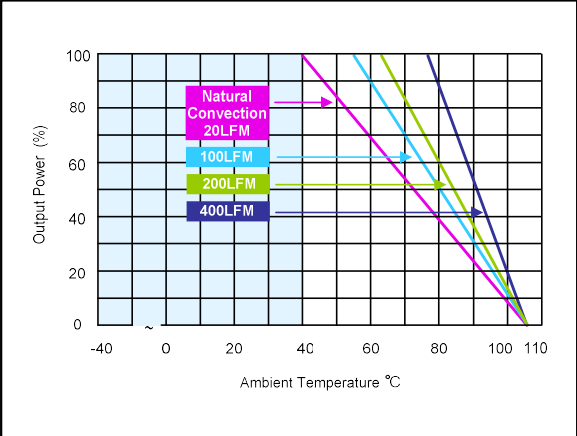

Figure 115: AEE01BB36-L Derating Curves (without heatsink)
 Vin = 48Vdc Load: Io = 0 to ±1.67A

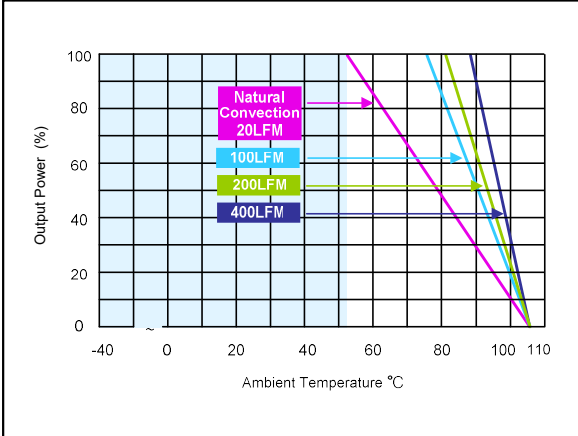

Figure 116: AEE01BB36-L Derating Curves (with heatsink)
 Vin = 48Vdc Load: Io = 0 to ±1.67A

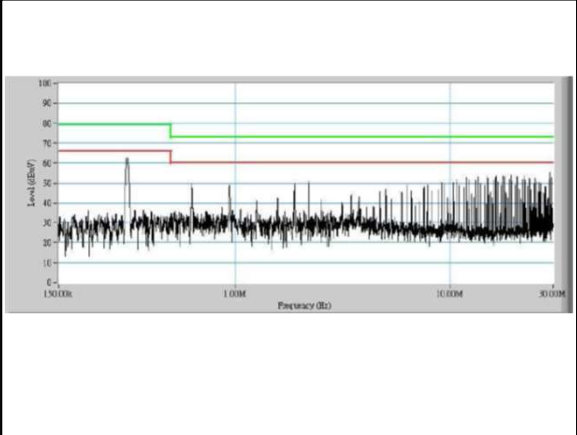

Figure 117: AEE01BB36-L Conduction Emission of EN550122 Class A
 Vin = 48Vdc Load: Io = ±1.67A

Note - All test conditions are at 25 °C

ELECTRICAL SPECIFICATIONS

AEE01CC36-L Performance Curves

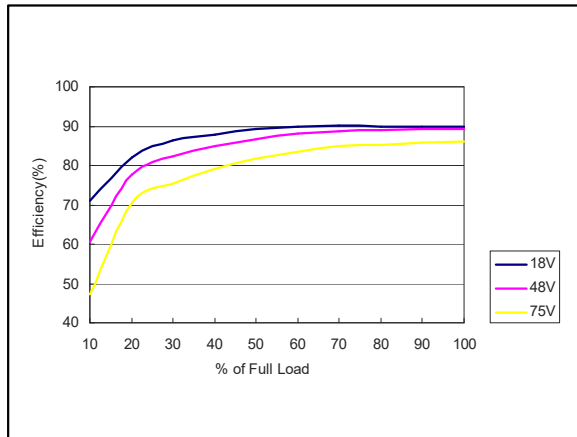

Figure 118: AEE01CC36-L Efficiency Versus Output Current Curve
 Vin = 18 to 75Vdc Load: Io = 0 to ±1.33A

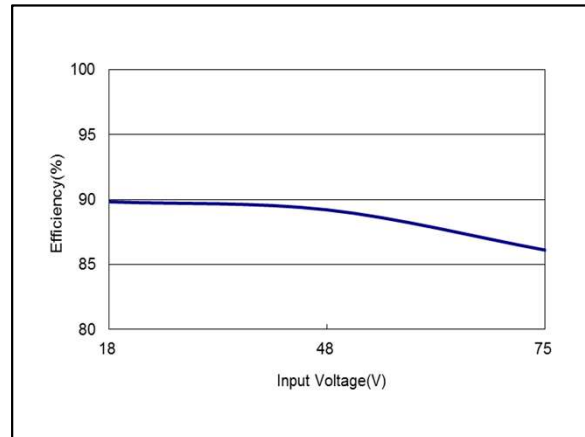

Figure 119: AEE01CC36-L Efficiency Versus Input Voltage Curve
 Vin = 18 to 75Vdc Load: Io = ±1.33A

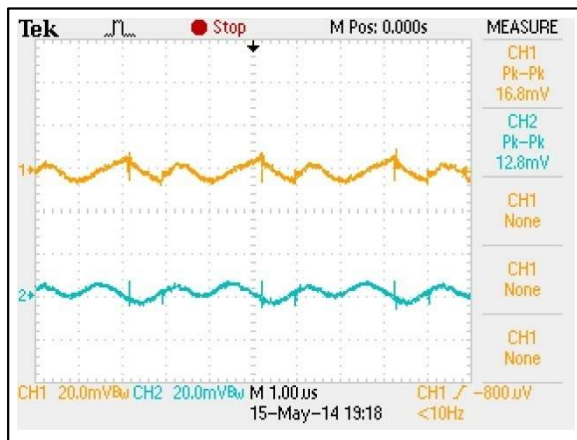

Figure 120: AEE01CC36-L Ripple and Noise Measurement
 Vin = 48Vdc Load: Io = ±1.33A
 Ch 1: Vo1 Ch 2: Vo2

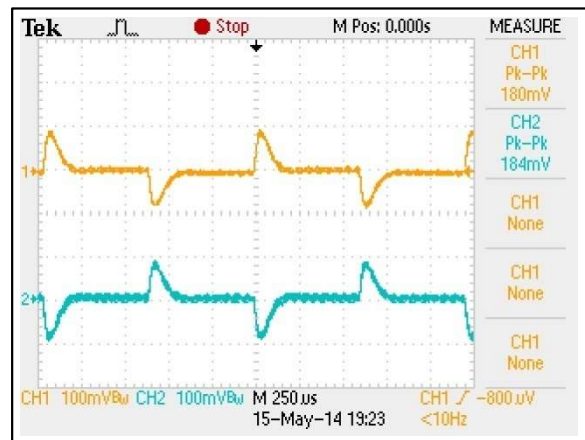

Figure 121: AEE01CC36-L Transient Response
 Vin = 48Vdc Load: Io = 100% to 75% load change
 Ch 1: Vo1 Ch 2: Vo2

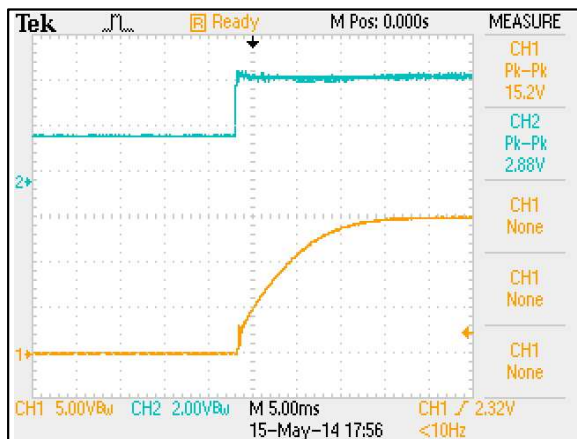

Figure 122: AEE01CC36-L Output Voltage Startup Characteristic by On/Off
 Vin = 48Vdc Load: Io = ±1.33A
 Ch 1: Vo Ch 2: Remote On/Off



Figure 123: AEE01CC36-L Output Voltage Startup Characteristic by Vin
 Vin = 48Vdc Load: Io = ±1.33A
 Ch 1: Vo Ch 2: Vin

ELECTRICAL SPECIFICATIONS

AEE01CC36-L Performance Curves

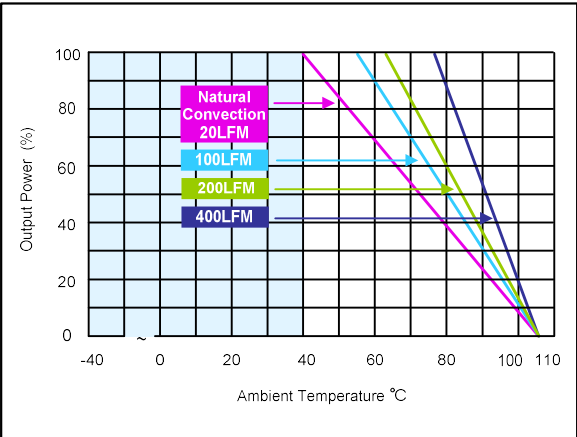

Figure 124: AEE01CC36-L Derating Curves (without heatsink)
Vin = 48Vdc Load: Io = 0 to ±1.33A

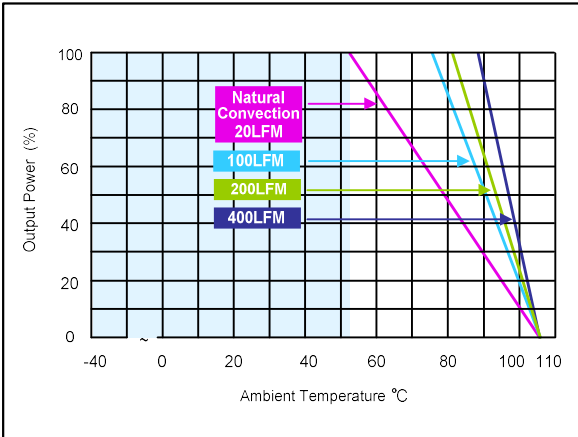

Figure 125: AEE01CC36-L Derating Curves (with heatsink)
Vin = 48Vdc Load: Io = 0 to ±1.33A

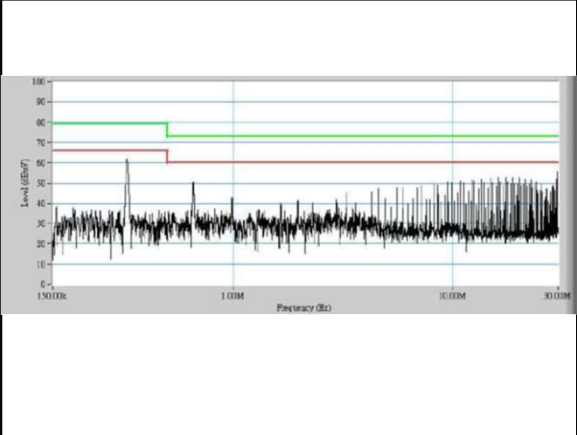
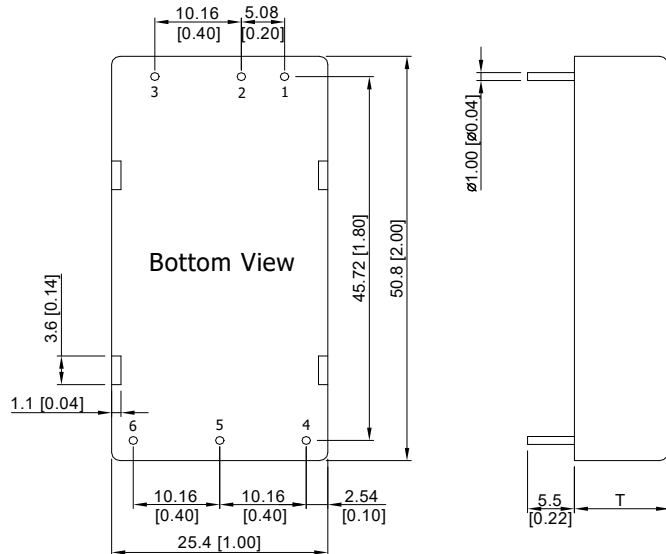

Figure 126: AEE01CC36-L Conduction Emission of EN550122 Class A
Vin = 48Vdc Load: Io = ±1.33A

Note - All test conditions are at 25 °C

MECHANICAL SPECIFICATIONS

Mechanical Outlines (unit: mm)



Note:

- 1.All dimensions in mm (inches)
- 2.Tolerance: X.X±0.25 (X.XX±0.01)
X.XX±0.13 (X.XXX±0.005)
- 3.Pin diameter 1.0 ±0.05 (0.04±0.002)

Pin Connections

Single output

- Pin 1 - +Vin
- Pin 2 - -Vin
- Pin 3 - Remote On/Off
- Pin 4 - +Vout
- Pin 5 - -Vout
- Pin 6 - Trim

Dual Output

- Pin 1 - +Vin
- Pin 2 - -Vin
- Pin 3 - Remote On/Off
- Pin 4 - +Vout
- Pin 5 - Common
- Pin 6 - -Vout

Physical Characteristics

Device code suffix	L
Case Size (24V Output)	50.8x25.4x11mm (2.0x1.0x0.43 inches)
Case Size (Other Output)	50.8x25.4x10.2mm (2.0x1.0x0.40 inches)
Case Material	Aluminium Alloy, Black Anodized Coating
Base Material	FR4 PCB (flammability to UL 94V-0 rated)
Pin Material	Copper Alloy with Gold Plate Over Nickel Subplate
Weight	30g

MECHANICAL SPECIFICATIONS

Recommended Pad Layout

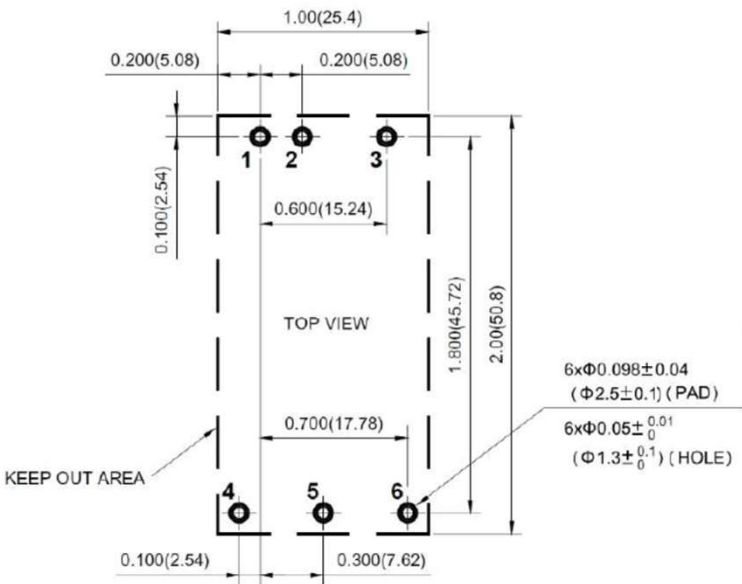

- 1. All dimensions in Inches (mm)
Tolerance: $x.xx \pm 0.02"$ ($x.x \pm 0.5$)
 $x.xxx \pm 0.01"$ ($x.xx \pm 0.25mm$)
- 2. Pin pitch tolerance: $\pm 0.01"$ ($\pm 0.25mm$)
- 3. Pin dimension tolerance: $\pm 0.004"$ ($\pm 0.1mm$)

MECHANICAL SPECIFICATIONS

Heatsink (Option - HS)

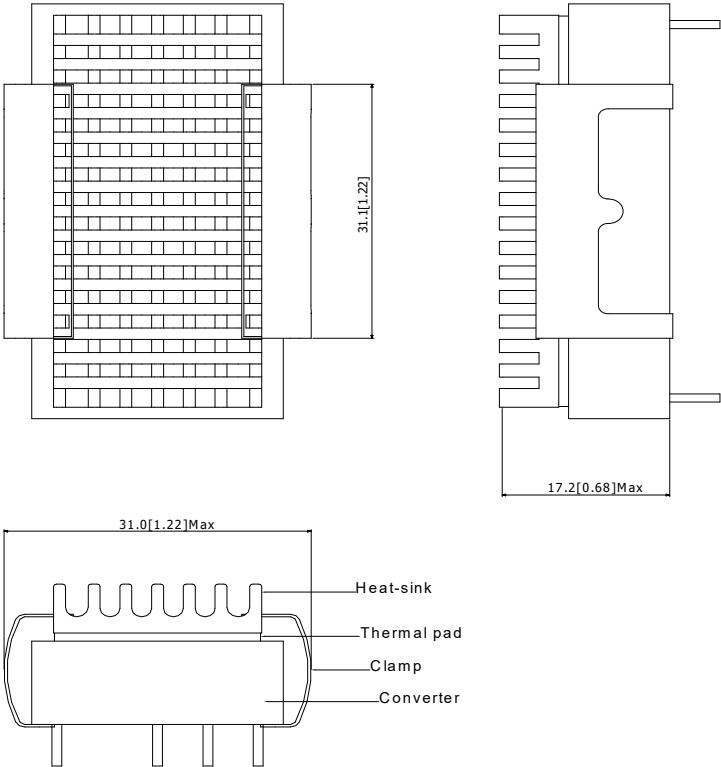

Heatsink Material: Aluminum
Finish: Black Anodized Coating
Weight: 9g

The advantages of adding a heatsink are:

1. To help heat dissipation and increase the stability and reliability of DC/DC converters at high operating temperature atmosphere.
2. To upgrade the operating temperature of DC/DC converters, please refer to Derating Curve

ENVIRONMENTAL SPECIFICATIONS

EMC Immunity

AEE 40W series power supply is designed to meet the following EMC immunity specifications.

Table 4. EMC Specifications		
Parameter	Standards & Level	Performance
EMI	EN55022	Class A
ESD	EN61000-4-2 air $\pm 8\text{KV}$, Contact $\pm 6\text{KV}$	Perf. Criteria A
Radiated immunity	EN61000-4-3 10V/m	Perf. Criteria A
Fast transient ¹	EN61000-4-4 $\pm 2\text{KV}$	Perf. Criteria A
Surge ¹	EN61000-4-5 $\pm 1\text{KV}$	Perf. Criteria A
Conducted immunity	EN61000-4-6 10Vrms	Perf. Criteria A

Note 1 - The AEE 40W series can meet EN61000-4-4 & EN61000-4-5 by adding a capacitor across the input pins. Suggested capacitor: CHEMI-CON KY 220 μF /100V.

ENVIRONMENTAL SPECIFICATIONS

EMC Considerations

EMI-Filter to meet EN 55022, class A, FCC part 15, level A

Conducted and radiated emissions EN55022 Class A

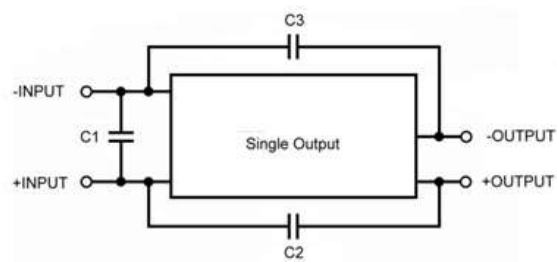

AEE Module Single output

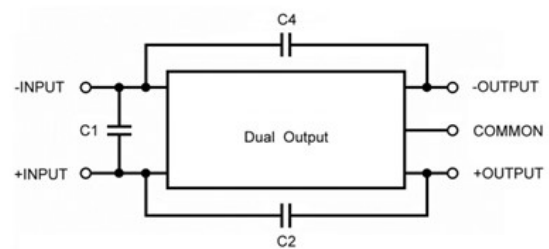

AEE Module Dual Output

Recommended circuit to comply EN55022 Class A limits

Table 5. Conducted EMI emission specifications

Component	9 - 36V Single	18 - 75V Single	9 - 36V Dual	18 - 75V Dual
C1	4.7 μ F/50V 1812 MLCC	2.2 μ F/100V 1812 MLCC	4.7 μ F/50V 1812 MLCC	2.2 μ F/100V 1812 MLCC
C2	1000pF/2KV 1808 MLCC	1000pF/2KV 1808 MLCC	1000pF/2KV 1808 MLCC	1000pF/2KV 1808 MLCC
C3	1000pF/2KV 1808 MLCC	1000pF/2KV 1808 MLCC	None	None
C4	None	None	1000pF/2KV 1808 MLCC	1000pF/2KV 1808 MLCC

ENVIRONMENTAL SPECIFICATIONS

Safety Certifications

The AEE 40W series power supply is intended for inclusion in other equipment and the installer must ensure that it is in compliance with all the requirements of the end application. This product is only for inclusion by professional installers within other equipment and must not be operated as a stand alone product.

Table 6. Safety Certifications for AEE 40W series power supply system	
Document	Description
cUL/UL 60950-1 (CSA certificate)	US and Canada Requirements
IEC/EN 60950-1 (CB-scheme)	European Requirements

ENVIRONMENTAL SPECIFICATIONS

Operating Temperature

Table 7. Operating Temperature					
Parameter	Model / Condition	Min	Max		Unit
			Without Heatsink	With Heatsink	
Operating Temperature Range (Natural Convection, see Derating)	AEE08F18-L	-40	66	73	°C
	AEE08A18-L		51	61	
	AEE03B18-L		51	61	
	AEE02C18-L		51	61	
	AEE01H18-L		57	66	
	AEE01BB18-L		40	52	
	AEE01CC18-L		40	52	
	AEE08F36-L		66	73	
	AEE08A36-L		51	61	
	AEE03B36-L		51	61	
	AEE02C36-L		51	61	
	AEE01H36-L		57	66	
	AEE01BB36-L		40	52	
	AEE01CC36-L		40	52	
Thermal Impedance	Natural Convection without Heatsink	12.0	-	-	°C/W
	Natural Convection with Heatsink	10.0	-	-	
	100LFM Convection without Heatsink	9.0	-	-	
	100LFM Convection with Heatsink	5.4	-	-	
	200LFM Convection without Heatsink	8.0	-	-	
	200LFM Convection with Heatsink	4.5	-	-	
	400LFM Convection without Heatsink	6.0	-	-	
400LFM Convection with Heatsink	3.0	-	-		
Case Temperature		-	105		°C
Thermal Protection	Shutdown Temperature		110		°C
Storage Temperature Range		-50	+125		°C
Humidity (non condensing)		-	95		%
RFI	Six-Sided Shielded, Metal Case				
Lead Temperature (1.5mm from case for 10Sec.)		-	260		°C

Note1 - The "natural convection" is about 20LFM but is not equal to still air (0 LFM).

ENVIRONMENTAL SPECIFICATIONS

MTBF and Reliability

The MTBF of AEE 40W series of DC/DC converters has been calculated using MIL-HDBK 217F NOTICE2, Operating Temperature 25 °C, Ground Benign

Model	MTBF	Unit
AEE08F18-L	720784	Hours
AEE08A18-L	401292	
AEE03B18-L	343923	
AEE02C18-L	348480	
AEE01H18-L	541511	
AEE01BB18-L	328170	
AEE01CC18-L	339416	
AEE08F36-L	603205	
AEE08A36-L	346962	
AEE03B36-L	408443	
AEE02C36-L	396294	
AEE01H36-L	551073	
AEE01BB36-L	330268	
AEE01CC36-L	330511	

APPLICATION NOTES

Input Reflected-Ripple Current Test Setup

Input reflected-ripple current is measured with an inductor L_{in} ($4.7\mu H$) and C_{in} ($220\mu F$, $ESR < 1.0\Omega$ at 100 KHz) to simulate source impedance. Capacitor C_{in} , offsets possible battery impedance. Current ripple is measured at the input terminals of the module, measurement bandwidth is $0\text{-}500\text{ KHz}$.

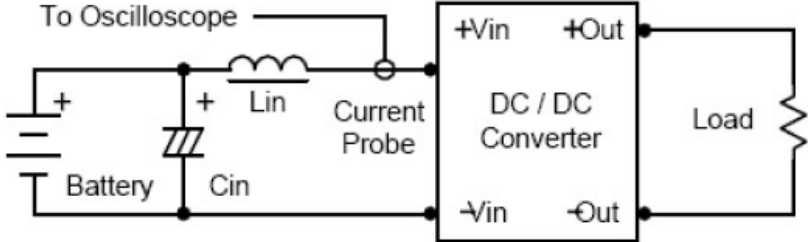

Component	Value	Reference
L_{in}	$4.7\mu H$	-
C_{in}	$220\mu F$ ($ESR < 1.0\Omega$ at 100 KHz)	Aluminum Electrolytic Capacitor

APPLICATION NOTES

Output Ripple Reduction

A good quality low ESR capacitor placed as close as practicable across the load will give the best ripple and noise performance. To reduce output ripple, it is recommended to use 4.7uF capacitors at the output.

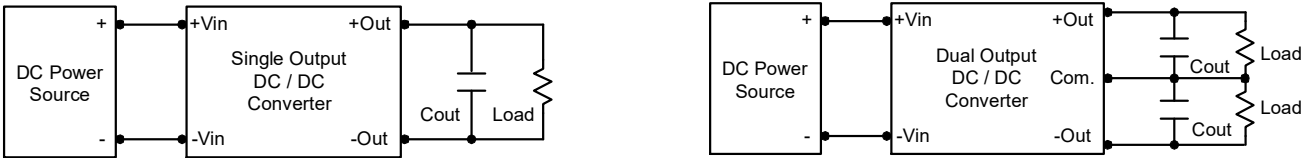

Peak-to-Peak Output Noise Measurement Test

Use a 1uF ceramic capacitor and a 10uF tantalum capacitor. Scope measurement should be made by using a BNC socket, measurement bandwidth is 0-20MHz. Position the load between 50 mm and 75 mm from the DC/DC Converter.

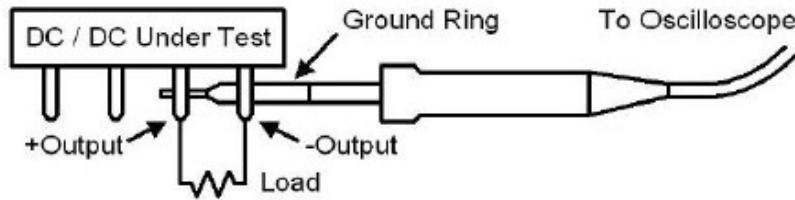
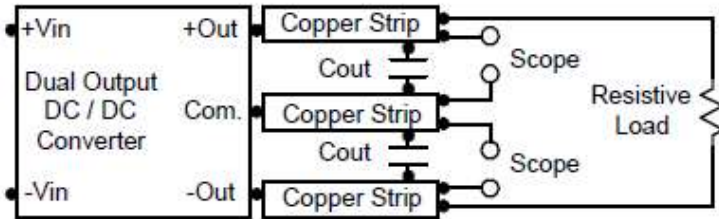
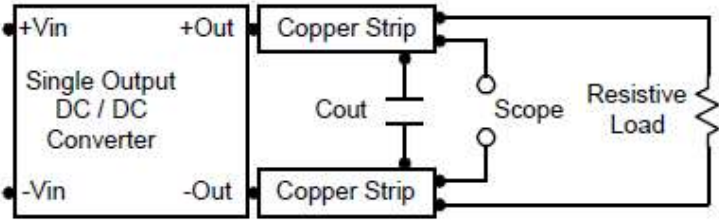

APPLICATION NOTES

Remote ON/OFF

Positive logic remote on/off turns the module on during a logic high voltage on the remote on/off pin, and off during a logic low. To turn the power module on and off, the user must supply a switch to control the voltage between the on/off terminal and the -Vin terminal. The switch can be an open collector or equivalent. A logic low is 0V to 1.2V. A logic high is 4.7V to 12V. The maximum sink current at the on/off terminal (Pin 3) during a logic low is -100μA. The maximum allowable leakage current of a switch connected to the on/off terminal (Pin 3) at logic high (2.5V to 100V) is 5μA.

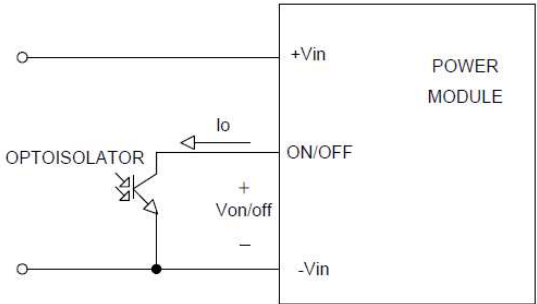

Isolated-Closure Remote ON/OFF

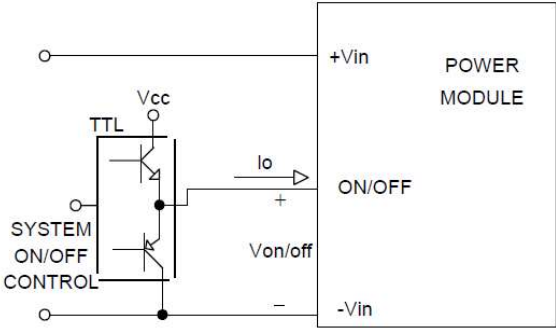

Level Control Using TTL Output

Application Notes

External Output Trimming

Output can be externally trimmed by using the method shown below. The trim up/down range is $\pm 10\%$ minimum of the nominal output voltage.

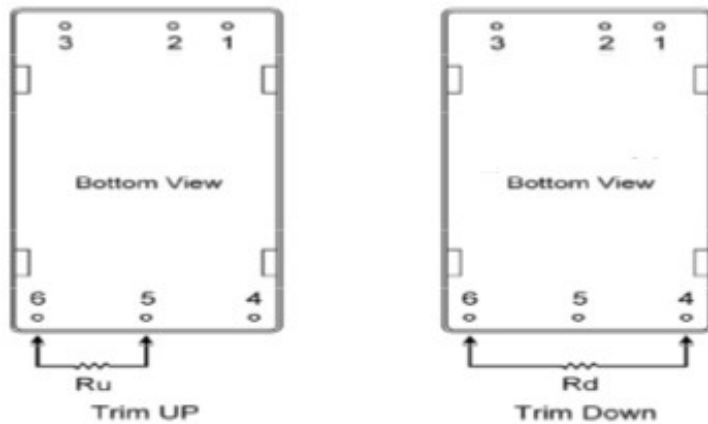

3.3V Output Trim Table

Trim down	1	2	3	4	5	6	7	8	9	10	%
Vout=	Vox0.99	Vox0.98	Vox0.97	Vox0.96	Vox0.95	Vox0.94	Vox0.93	Vox0.92	Vox0.91	Vox0.90	Volts
Rd=	63.59	30.28	18.19	11.95	8.13	5.56	3.70	2.31	1.21	0.34	KOhms
Trim up	1	2	3	4	5	6	7	8	9	10	%
Vout=	Vox1.01	Vox1.02	Vox1.03	Vox1.04	Vox1.05	Vox1.06	Vox1.07	Vox1.08	Vox1.09	Vox1.10	Volts
Ru=	60.84	27.40	16.25	10.68	7.34	5.11	3.51	2.32	1.39	0.65	KOhms

5.0V Output Trim Table

Trim down	1	2	3	4	5	6	7	8	9	10	%
Vout=	Vox0.99	Vox0.98	Vox0.97	Vox0.96	Vox0.95	Vox0.94	Vox0.93	Vox0.92	Vox0.91	Vox0.90	Volts
Rd=	45.53	20.61	12.31	8.15	5.66	4.00	2.81	1.92	1.23	0.68	KOhms
Trim up	1	2	3	4	5	6	7	8	9	10	%
Vout=	Vox1.01	Vox1.02	Vox1.03	Vox1.04	Vox1.05	Vox1.06	Vox1.07	Vox1.08	Vox1.09	Vox1.10	Volts
Ru=	36.57	16.58	9.92	6.59	4.59	3.25	2.30	1.59	1.03	0.59	KOhms

Application Notes

External Output Trimming Con't

12V Output Trim Table

Trim down	1	2	3	4	5	6	7	8	9	10	%
Vout=	Vox0.99	Vox0.98	Vox0.97	Vox0.96	Vox0.95	Vox0.94	Vox0.93	Vox0.92	Vox0.91	Vox0.90	Volts
Rd=	394.5	179.74	106.08	68.86	46.39	31.36	20.60	12.51	6.21	1.17	KOhms
Trim up	1	2	3	4	5	6	7	8	9	10	%
Vout=	Vox1.01	Vox1.02	Vox1.03	Vox1.04	Vox1.05	Vox1.06	Vox1.07	Vox1.08	Vox1.09	Vox1.10	Volts
Ru=	368.92	161.92	94.97	61.86	42.12	29.00	19.66	12.66	7.23	2.89	KOhms

15V Output Trim Table

Trim down	1	2	3	4	5	6	7	8	9	10	%
Vout=	Vox0.99	Vox0.98	Vox0.97	Vox0.96	Vox0.95	Vox0.94	Vox0.93	Vox0.92	Vox0.91	Vox0.90	Volts
Rd=	572.67	248.63	145.60	94.97	64.87	44.92	30.72	20.10	11.86	5.28	KOhms
Trim up	1	2	3	4	5	6	7	8	9	10	%
Vout=	Vox1.01	Vox1.02	Vox1.03	Vox1.04	Vox1.05	Vox1.06	Vox1.07	Vox1.08	Vox1.09	Vox1.10	Volts
Ru=	392.98	182.12	108.73	71.43	48.85	33.71	22.86	14.69	8.33	3.23	KOhms

24V Output Trim Table

Trim down	1	2	3	4	5	6	7	8	9	10	%
Vout=	Vox0.99	Vox0.98	Vox0.97	Vox0.96	Vox0.95	Vox0.94	Vox0.93	Vox0.92	Vox0.91	Vox0.90	Volts
Rd=	318.05	146.05	85.8	55.51	37.415	26.625	16.515	9.81	4.9785	0.9185	KOhms
Trim up	1	2	3	4	5	6	7	8	9	10	%
Vout=	Vox1.02	Vox1.04	Vox1.06	Vox1.08	Vox1.1	Vox1.12	Vox1.14	Vox1.16	Vox1.18	Vox1.20	Volts
Ru=	247.2	109.255	63.38	39.025	27.52	18.39	11.77	7.29	3.308	0.3658	KOhms

APPLICATION NOTES

Input Source Impedance

The power module should be connected to a low ac-impedance input source. Highly inductive source impedances can affect the stability of the power module.

In applications where power is supplied over long lines and output loading is high, it may be necessary to use a capacitor at the input to ensure startup.

Capacitor mounted close to the power module helps ensure stability of the unit, it is recommended to use a good quality low Equivalent Series Resistance ($ESR < 1.0\Omega$ at 100 KHz) capacitor of a $10\mu\text{F}$ for the 24V and 48V devices.

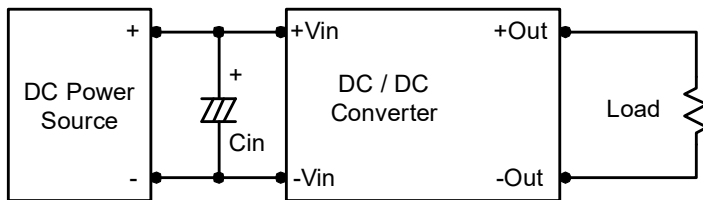

Output Over Current Protection

To provide hiccup mode protection in a fault (output overload) condition, the unit is equipped with internal current limiting circuitry and can endure overload for an unlimited duration.

Output Over Voltage Protection

The output overvoltage clamp consists of control circuitry, which is independent of the primary regulation loop, that monitors the voltage on the output terminals.

The control loop of the clamp has a higher voltage set point than the primary loop. This provides a redundant voltage control that reduces the risk of output overvoltage. The OVP level can be found in the output data.

Thermal Considerations

Many conditions affect the thermal performance of the power module, such as orientation, airflow over the module and board spacing. To avoid exceeding the maximum temperature rating of the components inside the power module, the case temperature must be kept below $105\text{ }^\circ\text{C}$. The derating curves are determined from measurements obtained in a test setup.

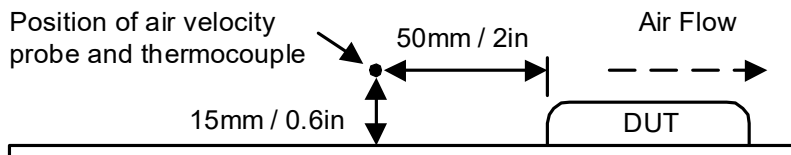

Maximum Capacitive Load

The AEE 40W series has limitation of maximum connected capacitance at the output. The power module may be operated in current limiting mode during start-up, affecting the ramp-up and the startup time. The maximum capacitance can be found in the Table 3.

APPLICATION NOTES

Packaging Information

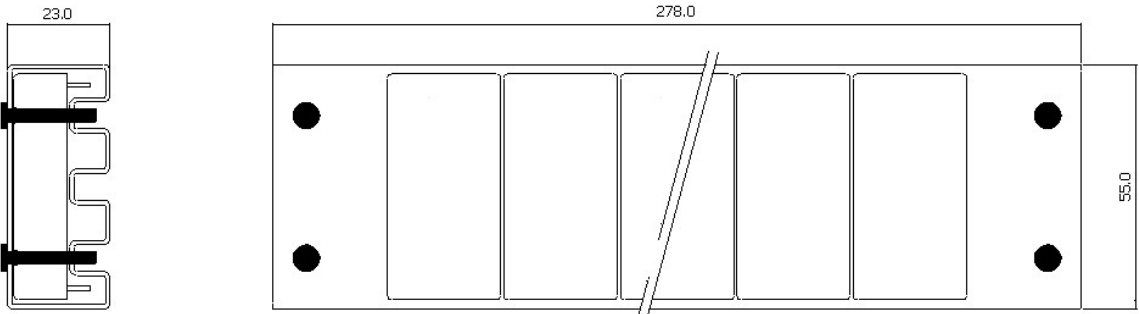

Soldering and Reflow Considerations

Lead free wave solder profile for AEE 40W Series

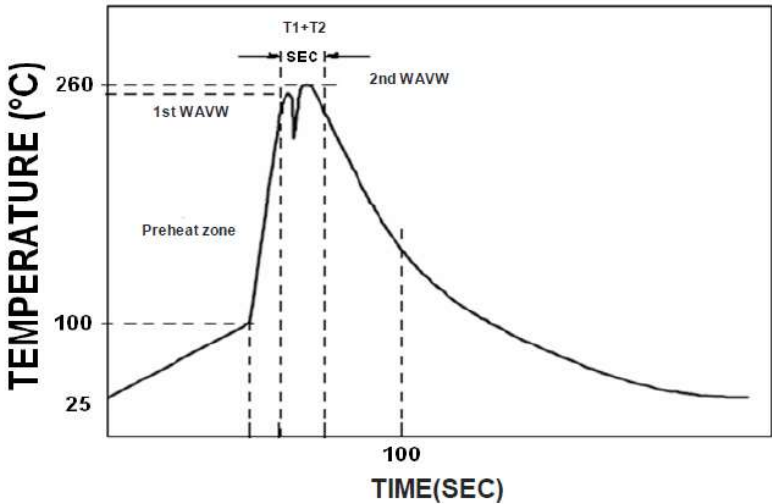

Zone	Reference Parameter
Preheat zone	Rise temp speed: 3°C/sec max.
	Preheat temp : 100~130°C
Actual heating	Peak temp: 250~260°C Peak Time
	Peak time(T1+T2): 4~6 sec

Reference Solder: Sn-Ag-Cu: Sn-Cu: Sn-Ag
 Hand Welding: Soldering iron: Power 60W
 Welding Time: 2~4 sec
 Temp.: 380~400 °C

RECORD OF REVISION AND CHANGES

Issue	Date	Description	Originators
1.0	10.24.2014	First Issue	K. Wang
1.1	09.10.2015	Updated the 24V module external trim range to 20% in section "Application Note"	K. Wang



For international contact information,
visit advancedenergy.com.

powersales@aei.com (Sales Support)
productsupport.ep@aei.com (Technical Support)
+1 888 412 7832

ABOUT ADVANCED ENERGY

Advanced Energy (AE) has devoted more than three decades to perfecting power for its global customers. AE designs and manufactures highly engineered, precision power conversion, measurement and control solutions for mission-critical applications and processes.

Our products enable customer innovation in complex applications for a wide range of industries including semiconductor equipment, industrial, manufacturing, telecommunications, data center computing, and medical. With deep applications know-how and responsive service and support across the globe, we build collaborative partnerships to meet rapid technological developments, propel growth for our customers, and innovate the future of power.

PRECISION | POWER | PERFORMANCE

Specifications are subject to change without notice. Not responsible for errors or omissions. ©2020 Advanced Energy Industries, Inc. All rights reserved. Advanced Energy®, and AE® are U.S. trademarks of Advanced Energy Industries, Inc.