

Polarity Reversing Configurations of UltraVolt HVPSs

In some electronics applications, a particular bias voltage may have to range from a positive voltage to a negative voltage or vice versa. The conventional solution is to utilize a high-voltage relay to reverse the polarity. However, this approach introduces a mechanical element to the system, which dramatically reduces the MTBF of the HVPS sub-system. This application note is presented as an illustration of a simple solution for low-current and electrostatic-bias applications. For higher current applications, contact the customer service department.

The simplest form of electronic polarity reversing is accomplished by using a positive supply and a negative supply, joined together through a pair of series resistors:

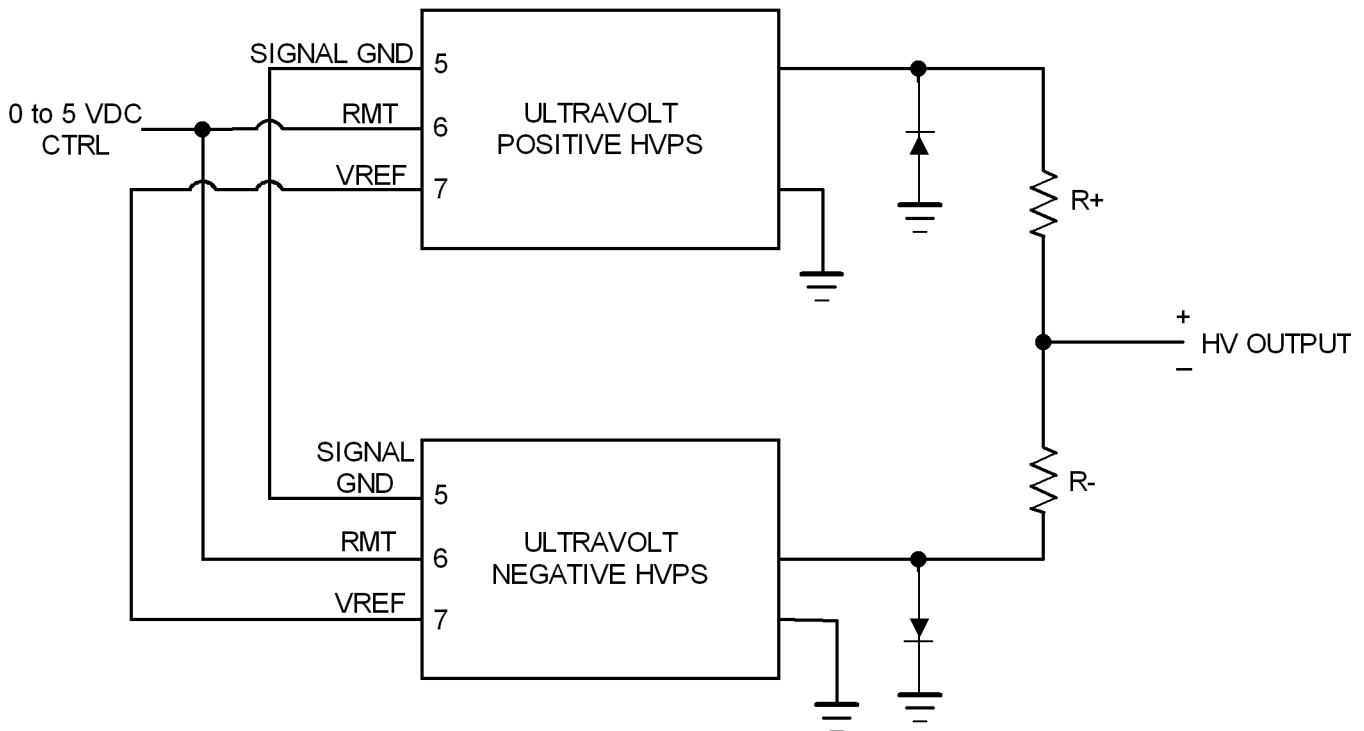

This configuration provides seamless control from 1/2 of the positive supply's maximum output voltage to 0 VDC to 1/2 of the negative supply's maximum output voltage. For example, an UltraVolt 4A12-P4 and 4A12-N4 combination would be adjustable from +2kV to -2kV. The supplies could be of the same voltage capability or could be selected to provide a limited range in one polarity. The resistors can be equal in value to provide an equal voltage range at either polarity, or they can be selected to limit the range of one polarity.

The diodes on the output of each HVPS are provided to sink the reverse current from the HVPS of the opposite polarity before it can reverse bias the circuitry inside the HVPS. These diodes should be rated a minimum of 150% of the maximum voltage, i.e., 6kV diodes when used with a 4kV circuit.

The HVPS control has an initial gain error of $\pm 1.0\%$. When tying the control pins of two HVPS together and driving them with a single signal, the error becomes $\pm 2.0\%$. This error can be minimized two ways. The first way is to use two independent control signals from two pots or two dacs, corrected to eliminate the error. The second way is to use a single control signal through two 'calibration' potentiometers, one for each HVPS. The potentiometers can be conventional or digitally controlled. These methods are effective whether the goal is 'factory' calibration during initial manufacturing or "recalibration" on each system power-up.

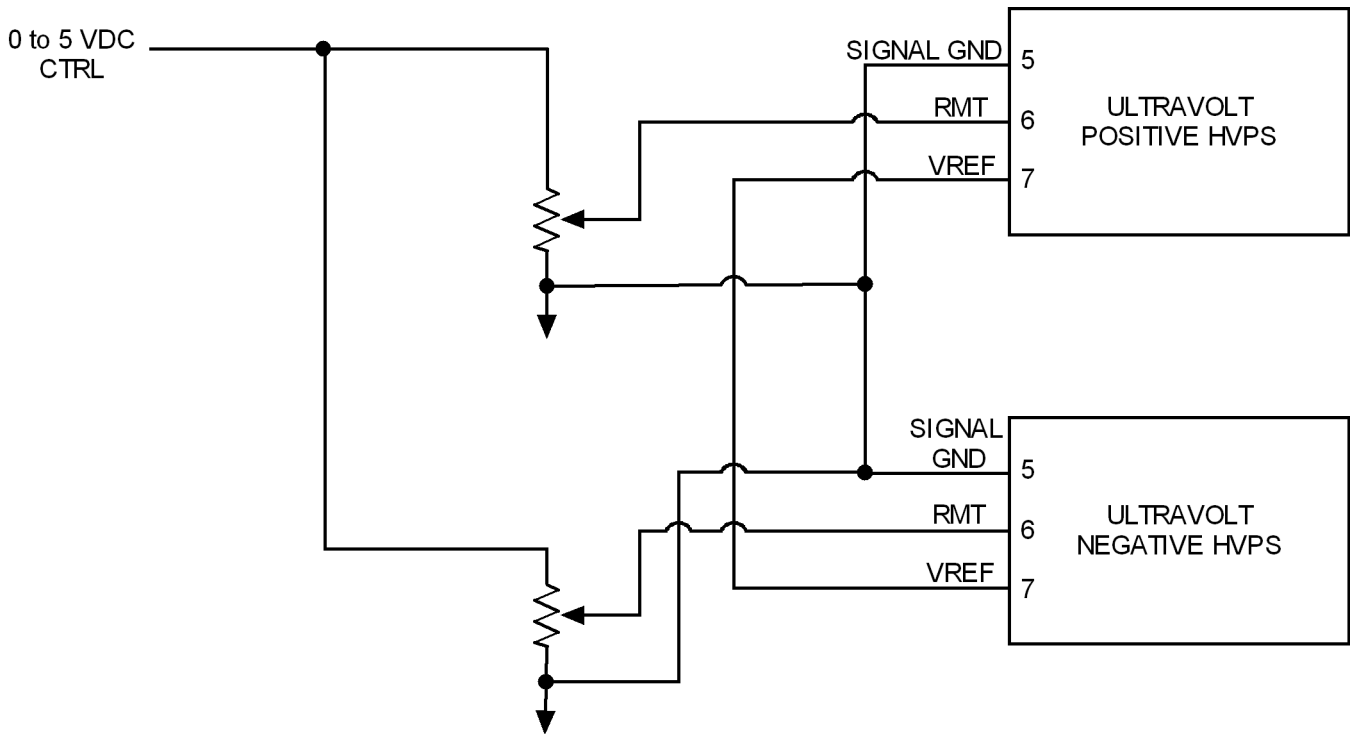

In low-noise systems the UltraVolt HVPS is normally ordered with the -F Ripple Stripper® Output Filter option and with the -M Mu-Metal shielding option. Since the output resistors isolate the HVPS from the load with a high impedance, this impedance can be used as an additional filter element with the addition of a single capacitor and resistor.

