

Low Cost Fiber Optic Hot Spot Monitor for OEM Integration



Key Features and Benefits

- Compatible with Double PFA Teflon® Jacketed, Kevlar® Cabled Fluoroptic® Rugged Probes™ and our Quality Probes™
- Probes are Immune to RF, Microwave and EMI Interference
- Solid State Long Life Fluoroptic® LED Light Source, No Lamps and No Replacement
- RS-232 and 0-10VDC, 0-1mA or 4-20mA Analog Output
- Compact Design with Din-Rail Mounting Options
- No Calibration Required
- Flexible Power Supply Options

Lowest Cost Module for OEMs

The m600 Utility Fluoroptic Technology (FOT) Module is LumaSense Technologies' cost effective integrated option for transformer hot spot monitoring. Specifically designed for integration by OEMs (transformer, control scheme, monitor etc.) desiring to add fiber optic temperature measurement capability to their equipment, the m600 Utility FOT Module comes housed in a compact, DIN-rail mountable enclosure that offers both RS-232 digital and analog outputs, and can be integrated easily with a standard PC or SCADA system.

At the heart of the m600 Utility FOT Module are the same core electronics used in LumaSense's high end, 4th generation WTS-22 hot spot monitor and controller and the new 8 channel ThermAsset2® hot spot monitor and controller. By offering just the core subsystem, it provides OEMs with the lowest material cost option and greatest flexibility for integration into their own control schemes. LumaSense Technologies' application engineers are available to assist with custom system integration.

Direct, Dynamic, Real Time

The m600 Utility FOT module allows direct, real time and accurate measurement of the transformer winding temperature. Conventional winding temperature indicators (WTIs) "infer" the hot spot temperature by measuring the transformer load on a single phase and the surrounding oil temperature and then modeling it. Studies have proven that there can be up to a five hour thermal lag between actual changes in hot spot temperatures versus when they are sensed by a WTI. Also, testing that has been performed can show a 5°C to 20°C difference between what is measured directly with fiber optics and the simulated value provided by WTI instrumentation. *The Result:* insulation damage and reduction in transformer life.

In contrast, the m600 Utility FOT Module measures the winding hot spot temperature directly. No models. No inferences. In real time. So your controllers and pumps can take action immediately, before your transformer assets are damaged.

Applications

- OEM Transformer Control Schemes
- OEM Monitoring Systems
- Load Tap Changers
- High Voltage Transmission Lines
- Research and Development Applications
- Any Low/High Voltage Equipment Application

Luxtron m600 Utility FOT Module

Specifications

Channels	1, 2 or 4
Measurement Range	-30 to 200°C
Electrical Interference	Probe Immune to EMI, Microwave and RF
Accuracy (Uncalibrated)	±2°C
Measurement Rate	1 to 4Hz per Channel, Configurable
Output Format	Selectable °C, °F and °K
Self Diagnostic	Self Diagnosis and Probe Errors Available on RS-232
Input Power	+24VDC ±5% @300mA & +5VDC on request
Serial Output	RS-232C
Analog Output	0-10V, 0-1mA or 4-20mA
Dimensions	74.7mm H x 44.7mm W x 104.5mm D
Storage Temperature	-30 to +75°C
Operating Environment	10°C to 50°C, 80% RH (Max) Non-condensing

Available Accessories

Description	Part Number
Mating Connector for Power Input and RS-232	47-1060-08
Mating Connector for Analog Outputs	47-1163
Wiring Pins for Mating Analog Output Connector	47-1162
DIN Rail Segment for Mounting	90-2176
Universal Switching Power Supply for 24V Version	08-14136-01

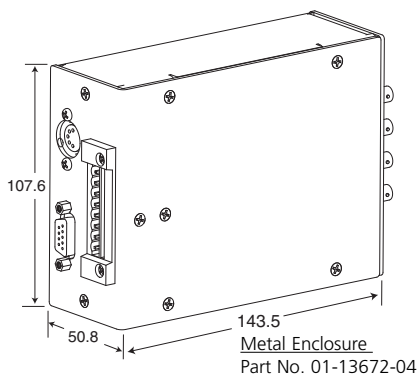

Field Proven Fluoroptic® Technology...for More than 25 Years

The m600 Utility FOT Module is based on the same patented Fluoroptic® technology as LumaSense Technologies' field proven WTS and ThermAsset2® hot spot monitoring and control systems. Fluoroptic® technology is inherently safe, reliable, stable and immune to EMI, RF and Microwave. Sensors are made of an inert dielectric compound attached directly to the end of the fiber optic probe and protected by the highest quality material available. When excited by the solid state LED light source, the temperature reading is dependent on decay time, an inherent property of the material, meaning no calibration is required.



3rd Generation Rugged Probes

LumaSense's 3rd generation Rugged Fluoroptic® Probes™ are flexible, armored and have a dual O-ring seal at the transformer tank wall interface. Made with an all-silica 200µm high voltage fiber and protected with Kevlar® and high grade PFA Teflon™, these probes are more flexible, stronger and more resilient than earlier generation probes. Also available with our new Quality Probes™.

Result: Probe installation success rate >99%.

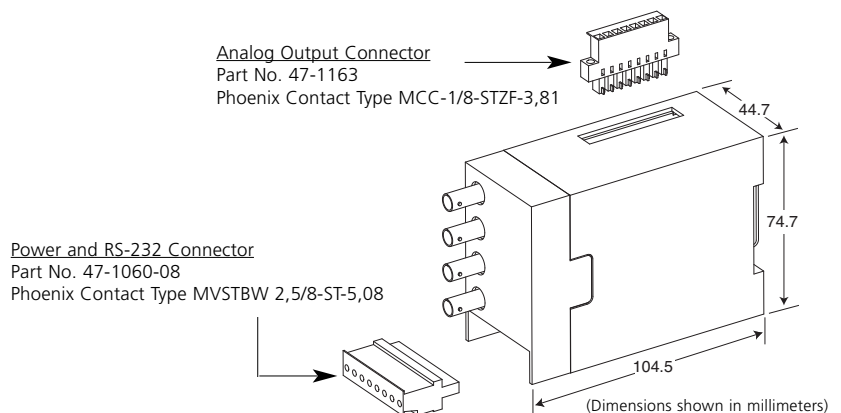

Specifications subject to change without notice. Luxtron and Fluoroptic are registered trademarks and TrueTemp is a trademark of LumaSense Technologies, Inc. ©2007 LumaSense Technologies, Inc. All rights reserved.