

### Introduction

In this technical note, we provide the connections, pins, and leads for the UltraVolt XS Series of microsize high-voltage power supplies. This document augments the datasheet. A complete datasheet can be found at [advancedenergy.com](http://advancedenergy.com).

The XS Series microsize units deliver 0 to 100VDC in a 0.1W miniature package. Output voltage polarity is fixed, either positive or negative. The input voltage available is  $5 \pm 0.5\text{VDC}$ .

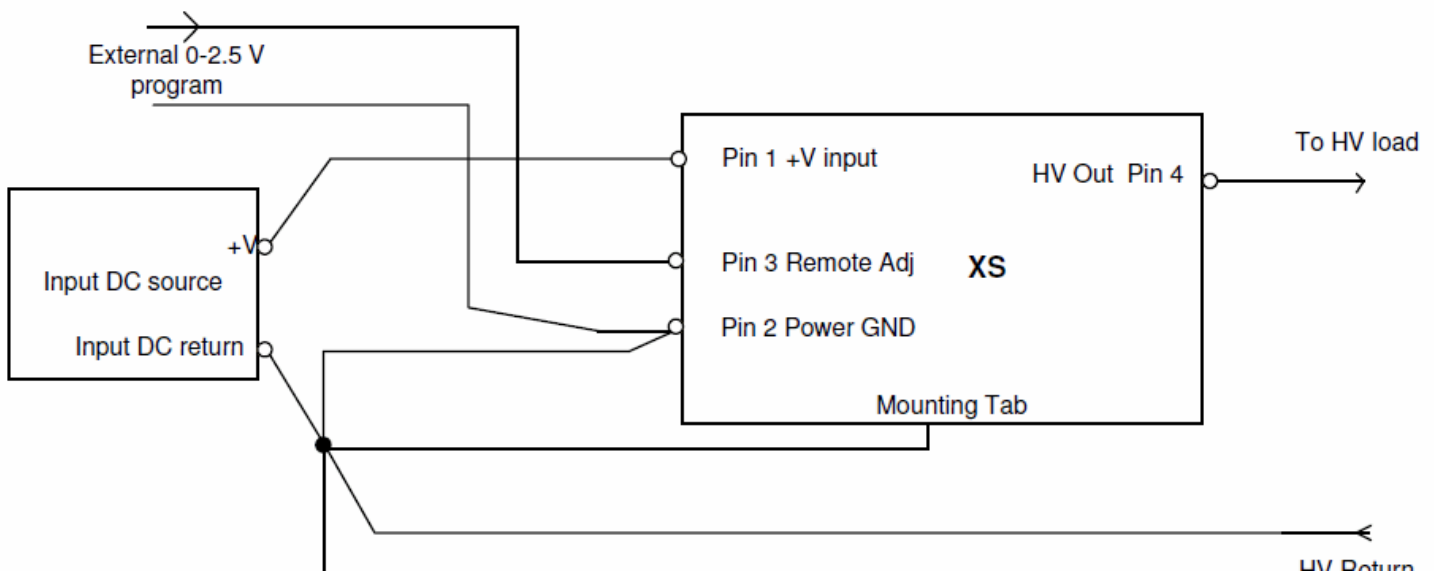

Figure 1: XS Series Functional Diagram

### Connections Overview

#### Pin 1, Positive power input:

This pin is the positive 5VDC input coming from the system AC/DC, DC/DC or battery low-voltage power source. The input source must be capable of providing at least 60mA (120% of the maximum input current required by the XS Series unit at full load).

#### Pin 2, Input Power Ground Return:

This pin is the return to the input DC source, the HV Return, and the return for the voltage control signal. This pin should be connected to the system common; however, care should be taken in making separate paths for the signal and HV Return in order to avoid interference.

**Pin 3, Control Input:**

This pin allows the control of the high-voltage output by a low-voltage signal. Using a 0 to 2.5V  $\pm 1\%$  positive voltage, the high voltage can be controlled from 0 to 100%. The control 2.5V signal source can be a DAC, op amp, etc. Pin 3 input impedance is 100k $\Omega$ . When zero volts is provided (or pin 3 is not connected), no output voltage will be present.

**Pin 4, High Voltage Output:**

This is the high-voltage output. The pin is located farther away from the other three pins in order to provide the proper clearance for the high voltage. When designing a system PC board, the proper creepage and clearance spacing must be observed.

**Case metal tabs:**

XS Series units are encapsulated in a tinned steel case with mounting tabs. The case and tabs are internally connected to the Input DC Return. It is recommended that tabs are soldered to the system ground plane. (See tab locations and dimension in the [datasheet](#)).