

ARTESYN iHP SERIES

Up to 24000 Watts Configurable Power System



iHP12

iHP24

PRODUCT DESCRIPTION

Advanced Energy’s Artesyn iHP series supports various methods of configuration and monitoring, including Ethernet (optional EtherCAT), RS485 and CAN communication. Systems should not use several protocols in parallel as this may produce unexpected results.

The default iHP comes with an Ethernet. It uses the standard UDP communication method and many available command codes are based on PMBus™ protocol, although some changes have been made to better fit the UDP transport mechanism.

An optional interface has been designed to support EtherCAT communication. The choice between EtherCAT and Ethernet depends on the specific needs of the application, including speed, complexity, and real-time performance requirements.

CONTENT

- Communication Interface
- WebTool
- PMBus™ Command List

AT A GLANCE

Total Power

Up to 24000 Watts

Input Voltage

180 to 264 Vac

342 to 528 Vdc

Single or 3-Phase for iHP12

3-Phase for iHP24

540 to 660Vac

3-Phase for iHP24C

of Outputs

Up to 8



Communication Interface Support - Default Ethernet

iHP RACK Communication Interface

There're four types of rack communication connectors. These RACK signals are isolated from Module's signal (J1 and J2 connector).

iHP RACK Port	Connector	Functions
USB PORT	Standard USB	For future expansion
ETHERNET Port	8Pin RJ45	LAN Port for Ethernet communication
RS485/CAN Port	6Pin RJ11	Use for RS485 and CAN communication
TTL	DSUB9	Provide logic signals

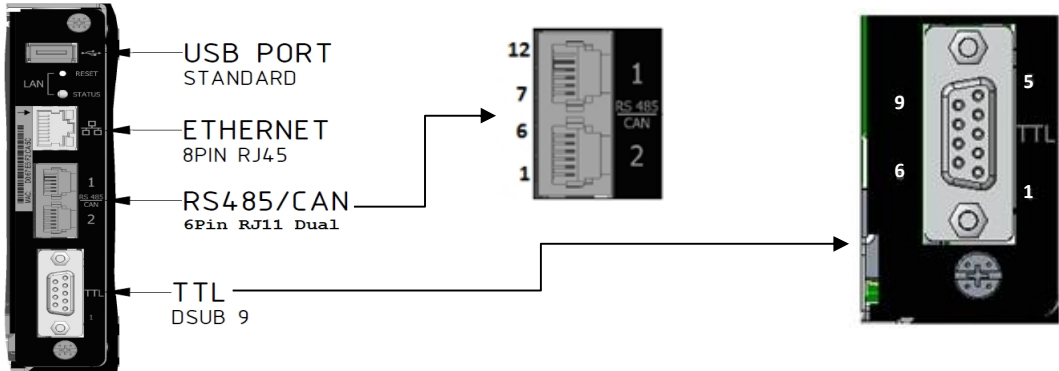

The Location of the Communication Port on Case



iHP12



iHP24

Communication Interface Support - Default Ethernet

Pin Assignment

iHP RACK Connector	Pin Number	Designation	Functions
USB Port	1	VCC	+5Vdc
	2	D-	Data-
	3	D+	Data+
	4	GND	Ground
RJ45 (Ethernet port)	1	TX+_D1	Transmit Data+
	2	TX-_D1	Transmit Data-
	3	RX+_D2	Receive Data+
	4	BI+_D3	Bi-directional+
	5	BI-_D3	Bi-directional-
	6	RX-_D2	Receive Data-
	7	BI+_D4	Bi-directional+
	8	BI-_D4	Bi-directional-
RJ11 (RS485/CAN)	1, 7	CANL	CAN communication lines
	2, 8	CANH	CAN communication lines
	3, 9	GND	Common ground for RS485 or CAN communication. Internally connected to DSUB9 pin2 5V Housekeeping Bias Return
	4, 10	5V Housekeeping bias	Supply Bias for CAN and RS485 communication. Internally connected to DSUB9 pin1 5V Housekeeping Bias
	5, 11	RS485_A	RS485 communication lines
	6, 12	RS485_B	RS485 communication lines
DSUB9 (TTL)	1	5V Housekeeping Bias	5V supply to power up system side circuits
	2	5V Housekeeping Bias Return	Ground reference of the 5V Housekeeping Bias
	3	Spare (Not Connected)	NA
	4	Global Inhibit/Enable Logic "1"	Signal can be configured either Inhibit logic High or Enable logic High
	5	Global Inhibit/Enable Logic "0"	Signal can be configured either Inhibit logic Low or Enable logic Low

Communication Interface Support - Default Ethernet

Pin Assignment

iHP RACK Connector	Pin Number	Designation	Functions
DSUB9 (TTL)	6	ACOK- "Emitter"	Use for ACOK signal
	7	ACOK+ "Collector"	Use for ACOK signal
	8	Global DC OK- "Emitter"	Use for DCOK signal
	9	Global DC OK+ "Collector"	Use for DCOK signal

WebTool

iHP rack has a built in WebTool to edit its configuration which can be changed using internet browser. The recommended internet browser is Chrome browser.

ISOCOMM WebTool is composed of different section, including Home section, Network section, Rack section, Module section, Firmware section and Maintenance section. The default settings for each section are as below.

ISOCOMM WebTool Section	User Configurable Parameter	Default Setting when shipped out from Artesyn Factory
Network	DHCP	Disable
	Static IP Address	192.168.2.100
	CAN/RS485 Rack Address	0
Rack	Internal Ambient Temperature OTP	62°C
	INH0/EN0 TTL Function	Inhibit
	INH1/EN1 TTL Function	Inhibit
	Wait for Power Switch	Enable
	Disable on 5V_STBY Fault	Disable
	Rack Synchronized Off	Disable
	Numbers of Racks Connected	1
Module	Module Synchronized Off	Enable
	Module Grouping	No Grouping

WebTool

Access the ISOCOMM Webtool

Open browser, and type the iHP rack IP address to access the WebTool. User will see the iHP rack homepage.

The screenshot shows a web browser window with the address bar set to 192.168.2.100. The page title is "iHP RACK IP Address". The browser tabs include "iHP Rack - Home", "iHP Rack - 100", "iHP Rack - 24", "iHP Rack - 221", and "192.168.2.51".

The main content area features the **ARTESYN EMBEDDED TECHNOLOGIES** logo and a navigation menu with the following items: HOME, NETWORK, RACK, MODULE, FIRMWARE, and MAINTENANCE. The "HOME" item is highlighted with a blue box.

The page is titled "WebTool Section" and displays the following information:

ISOCOMM :

MAC Address :	20:CD:39:F2:16:11
IP Address :	192.168.2.100
COMMS Firmware Version:	03.00.00
PFC1 Firmware Version:	02.06.00
PFC2 Firmware Version:	02.06.00

Modules :

Module	Model	Firmware Version
Module 1:	0	0
Module 2:	0	0
Module 3:	0	0
Module 4:	0	0
Module 5:	73-936-0048	04.05.10
Module 6:	0	0
Module 7:	0	0
Module 8:	0	0

Racks Connected :

IP Address	Serial Number	Status
192.168.2.201	837	Good
192.168.2.202	836	Good

Copyright © 2015 | Artesyn Embedded Technologies | All Rights Reserved

WebTool

Home Section

WebTool Home section will display the following information.

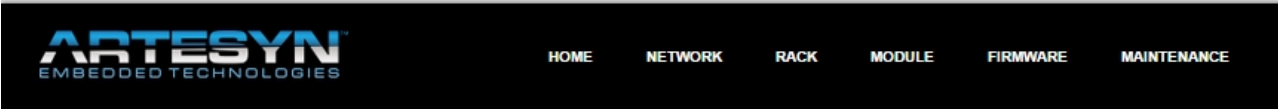

ISOCOMM :

MAC Address :	20:CD:39:F2:16:11
IP Address :	192.168.2.100
COMMS Firmware Version:	03.00.00
PFC1 Firmware Version:	02.06.00
PFC2 Firmware Version:	02.06.00

Modules :

Module 1:	Model:	0
	Firmware Version:	0
Module 2:	Model:	0
	Firmware Version:	0
Module 3:	Model:	0
	Firmware Version:	0
Module 4:	Model:	0
	Firmware Version:	0
Module 5:	Model:	73-936-0048
	Firmware Version:	04.05.10
Module 6:	Model:	0
	Firmware Version:	0
Module 7:	Model:	0
	Firmware Version:	0
Module 8:	Model:	0
	Firmware Version:	0

Racks Connected :

IP Address	Serial Number	Status
192.168.2.201	837	Good
192.168.2.202	836	Good

“Racks Connected” is active when Rack Synchronize Off is enabled in WebTool RACK Configuration. This function is needed during Multi-RACK operation. In above table, there are 3 iHP racks in Multi Rack Operation. The WebTool displays the IP address of the other 2 racks connected.

WebTool

Network Section

WebTool Network section will display the following information.



Network Configuration

Ethernet Settings:

MAC Address :	20:CD:39:F2:10:F2
Current IP Address :	10.162.140.221
Broadcast Address :	10.162.141.255
DHCP :	Enabled ▾
Static IP Address :	<input type="text" value="192"/> <input type="text" value="168"/> <input type="text" value="2"/> <input type="text" value="100"/>

CAN/RS485 Settings:

Rack Address:	0 ▾
---------------	-----

Changes to this page will be reflected after reboot.
 If you change the IP Address, remember to change the WEB URL when accessing this page.

DHCP

This will allow user to enable or disable Dynamic Host Configuration Protocol.

Setting	Remarks
Enable	The router will automatically assign the IP address to the iHP RACK. Once the setting is activated, user will need to search for the IP address assigned by the router.
Disable	IP address will be set to Static IP. User can update IP address in the "Static IP Address" field.

Static IP Address

This field will be used to enter user static IP address. This is applicable when the DHCP setting is disabled.

CAN/RS485 Setting

This field will be used to configure CAN / RS485 address. A drop down list will be available. CAN broadcast address is set to address 7. RS485 does not have any broadcast address.

CAN/RS485 Settings:

Rack Address:	<div style="border: 1px solid black; padding: 2px;"> <div style="background-color: #f0f0f0; padding: 2px;">0 ▾</div> <div style="padding: 2px;">0</div> <div style="padding: 2px;">1</div> <div style="padding: 2px;">2</div> <div style="padding: 2px;">3</div> <div style="padding: 2px;">4</div> <div style="padding: 2px;">5</div> </div>
---------------	---

Changes to this page will be reflected after reboot.
 If you change the IP Address, remember to change the WEB URL when accessing this page.

WebTool

Rack Section

WebTool Rack section will display the following information.

Rack Configuration

Ambient Temperature OTP :	58 ▼
INH0/EN0 TTL Function :	Inhibit ▼
INH1/EN1 TTL Function :	Inhibit ▼
Wait for Power Switch :	Disable ▼
Disable on 5v_STBY Fault :	Disable ▼
<hr/>	
Rack Synchronized OFF:	Enable ▼
Number of Racks connected :	3 ▼

Note: You may need to restart the system in order for the changes to take effect.

[Restore previous values](#) [Save Changes](#)

Internal Ambient Temperature OTP

This configuration allows the user to set for the desired ambient temperature in which the rack will trigger the OTP. The user can set the Ambient OTP from 0-70 °C. OT warning will be flagged when the temperature reaches Ambient OTP less 4 °C. Ambient temperature monitoring is located on the Front Panel of iHP Rack. Once Ambient OTP is triggered, status will be reflected on the ISOCOMM PMBus™ STATUS_TEMPERATURE.

Wait For Power Switch

Power Switch is located on the front panel of the iHP unit. Enabling this configuration will allow the user to wait for the power switch to be pressed before the iHP rack turns on after the application of the AC input voltage.

Setting	Remarks
Enable	After turning-on the Input AC and ISOCOMM Boot load, Modules will not turn-on. Module will turn-on after pressing the Standby Switch. Power Switch will be operational after 20secs from the application of input AC.
Disable	After turning-on the Input AC and ISOCOMM Boot load, Modules will turn-on automatically.

Disable on 5V_STBY Fault

User can configure the iHP rack to disable the modules if 5V_STBY fault occurred.

Setting	Remarks
Enable	Once the 5V_STBY Fault occurred, modules will be disabled.
Disable	Once the 5V_STBY fault occurred, modules are still enabled.

WebTool

INH0/EN0 TTL and INH1/EN1 TTL Function

This section allows the user to configure INH0/EN0 TTL signal (iHP rack DSUB9 pin 5) as Inhibit Low or Enable Low function and INH1/EN1 TTL signal (iHP rack DSUB9 pin 4) as Inhibit High or Enable High function.

Configuration	iHP Rack DSUB9		Module Status
	Input to INH0/EN0 Pin 5	Input to INH1/EN1 Pin 4	
INH0 & INH1	Shorted to GND	Floating	OFF
	Shorted to GND	5V	OFF
	Floating	Floating	ON
	Floating	5V	OFF
INH0 & EN1	Shorted to GND	Floating	OFF
	Shorted to GND	5V	OFF
	Floating	Floating	OFF
	Floating	5V	ON
EN0 & INH1	Shorted to GND	Floating	ON
	Shorted to GND	5V	OFF
	Floating	Floating	OFF
	Floating	5V	OFF
EN0 & EN1	Shorted to GND	Floating	OFF
	Shorted to GND	5V	ON
	Floating	Floating	OFF
	Floating	5V	OFF

WebTool

Rack Synchronized Off

This function is needed during multi-rack operation. Number of Racks connected will be activated when the Rack Synchronized OFF is enabled.

This parameter will indicate how many racks should be synchronized. Allowable rack to be synchronized is up to 8 racks.

Rack Synchronisation :

Rack Synchronized OFF:	Enable ▾
Number of Racks connected :	1 ▾

Note: You need to restart the system in order for the changes to take effect.

- 1
- 2
- 3
- 4
- 5
- 6

Restore previous values Save Changes

Rack Synchronized Off Setting	Remarks
Enable	Rack synchronize off is activated.
Disable	Rack synchronize off is de-activated.

WebTool

Module Section

Module section will display the following information.

Module Configuration

Module Synchronized OFF :	Enabled ▼
---------------------------	-----------

Note: You may need to restart the system in order for the changes to take effect.

[Restore previous values](#) [Save Changes](#)

Group 1:	Configuration :	Series ▼
	Modules :	<input type="checkbox"/> Module 1 <input type="checkbox"/> Module 2 <input type="checkbox"/> Module 3 <input type="checkbox"/> Module 4 <input type="checkbox"/> Module 5 <input type="checkbox"/> Module 6 <input type="checkbox"/> Module 7 <input type="checkbox"/> Module 8
Group 2:	Configuration :	Series ▼
	Modules :	<input type="checkbox"/> Module 1 <input type="checkbox"/> Module 2 <input type="checkbox"/> Module 3 <input type="checkbox"/> Module 4 <input type="checkbox"/> Module 5 <input type="checkbox"/> Module 6 <input type="checkbox"/> Module 7 <input type="checkbox"/> Module 8
Group 3:	Configuration :	Series ▼
	Modules :	<input type="checkbox"/> Module 1 <input type="checkbox"/> Module 2 <input type="checkbox"/> Module 3 <input type="checkbox"/> Module 4 <input type="checkbox"/> Module 5 <input type="checkbox"/> Module 6 <input type="checkbox"/> Module 7 <input type="checkbox"/> Module 8
Group 4:	Configuration :	Series ▼
	Modules :	<input type="checkbox"/> Module 1 <input type="checkbox"/> Module 2 <input type="checkbox"/> Module 3 <input type="checkbox"/> Module 4 <input type="checkbox"/> Module 5 <input type="checkbox"/> Module 6 <input type="checkbox"/> Module 7 <input type="checkbox"/> Module 8
Group 5:	Configuration :	Series ▼
	Modules :	<input type="checkbox"/> Module 1 <input type="checkbox"/> Module 2 <input type="checkbox"/> Module 3 <input type="checkbox"/> Module 4 <input type="checkbox"/> Module 5 <input type="checkbox"/> Module 6 <input type="checkbox"/> Module 7 <input type="checkbox"/> Module 8
Group 6:	Configuration :	Series ▼
	Modules :	<input type="checkbox"/> Module 1 <input type="checkbox"/> Module 2 <input type="checkbox"/> Module 3 <input type="checkbox"/> Module 4 <input type="checkbox"/> Module 5 <input type="checkbox"/> Module 6 <input type="checkbox"/> Module 7 <input type="checkbox"/> Module 8
Group 7:	Configuration :	Series ▼
	Modules :	<input type="checkbox"/> Module 1 <input type="checkbox"/> Module 2 <input type="checkbox"/> Module 3 <input type="checkbox"/> Module 4 <input type="checkbox"/> Module 5 <input type="checkbox"/> Module 6 <input type="checkbox"/> Module 7 <input type="checkbox"/> Module 8

Note: You may need to restart the system in order for the changes to take effect.

[Restore previous values](#) [Save Changes](#)

WebTool

Module Synchronized OFF

This function will shutdown all modules installed in a rack when any module is at fault or in standby mode. User can configure this function as below table. It is required to enable the “Module Synchronized OFF” functionality when module is connected in parallel or series.

Setting	Remarks
Enable	All modules installed in the rack will shutdown when any module is at fault or in standby mode.
Disable	When at least one module is at fault or in standby, the remaining modules will still be operational.

Module Group

Modules need to be group as one during parallel or series connections. Modules will be allowed to be included in one group only.

This function will treat all modules as one. The group number and modules in the group connection parallel or series need to be configured in the ISOCOMM WebTool.

User can now have below added functions:

Single command for all modules in a group (limited command).

Single PMBus™ status reporting for all modules in a group.

Single reporting of Vo, Io, and Po for all modules in a group.

WebTool

Firmware Section

This section provides the firmware upgrade of PFC and modules. Before upgrading the firmware, module output should be disconnected to system load.

Procedure for firmware upgrade:

1. Click "FIRMWARE" tab. If asked for username and password, type below:

User Name: admin

Password: rtsn1234!

2. To upgrade the firmware of the unit, upload first the desired firmware file. Click "Choose File".

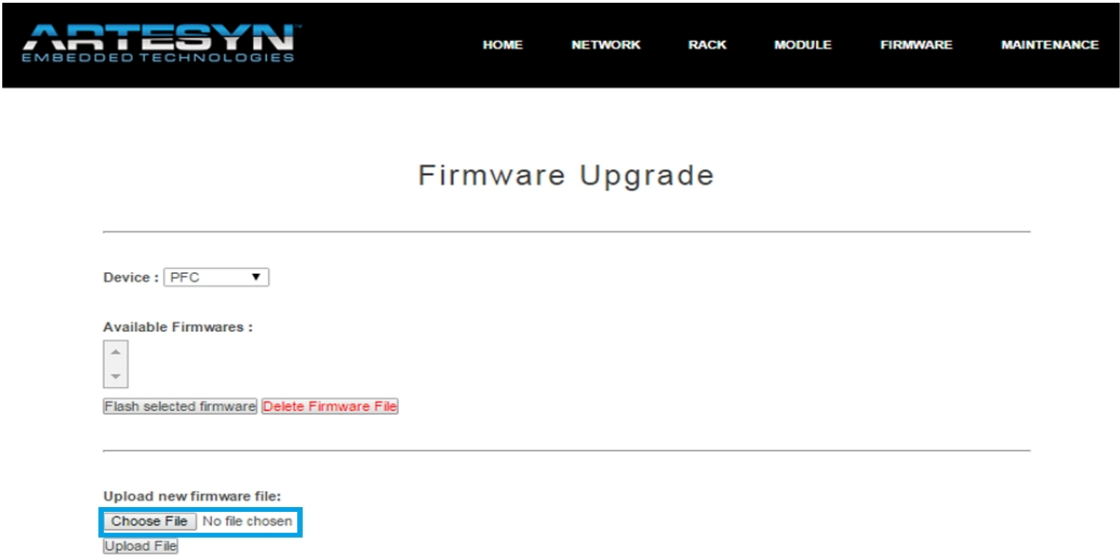

3. Select the desired firmware file. It is the .S extension file.

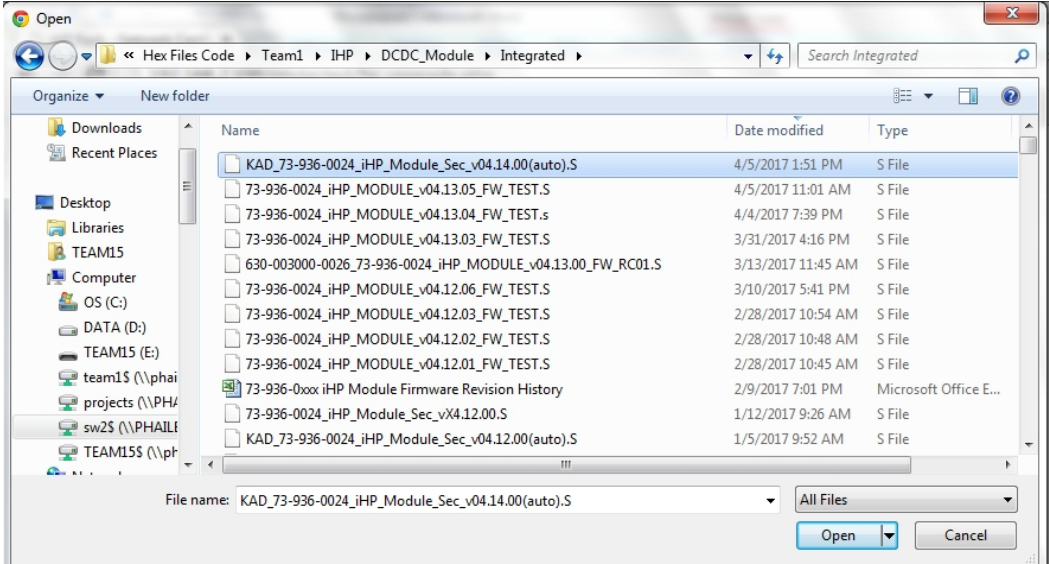

WebTool

4. Click "Upload File".



5. Once uploaded successfully, confirmation will be displayed as below.

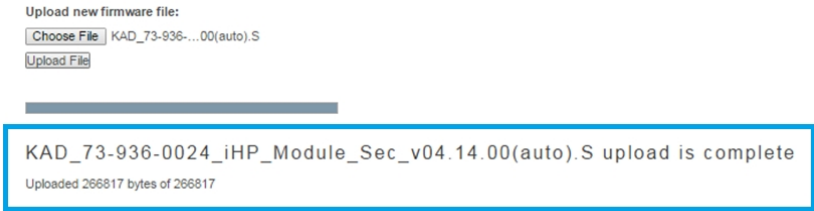

6. Refresh Webtool.

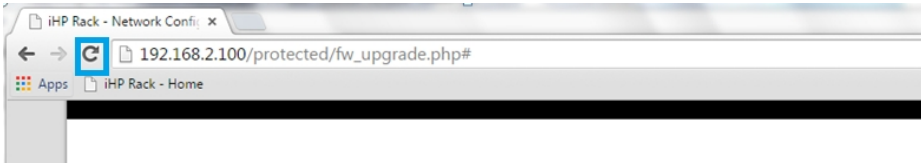

7. The uploaded file should be visible in the available firmware box.

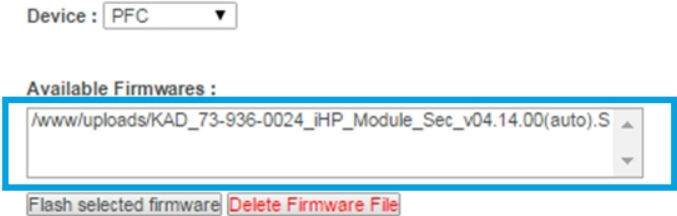

8. Select the preferred device (i.e. PFC or Module 1 or Module 2, ... or Module 8) to upgrade. Module bootloading should be done per module, so only select one module at a time.

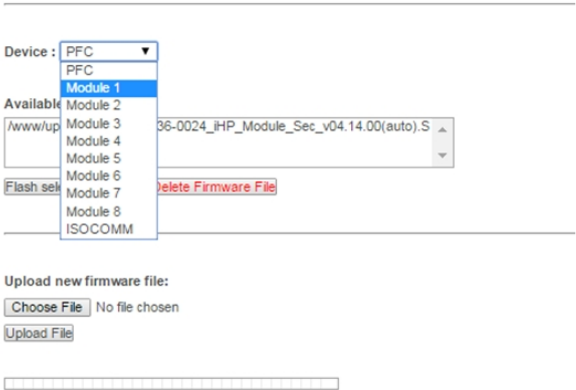

WebTool

9. Select the desired FW to be bootloaded at the Available Firmware box. It should be highlighted as below.

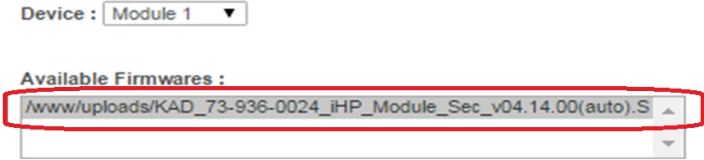

10. Click "Flash selected firmware" to start the bootloading. Bootloading progress will be display.

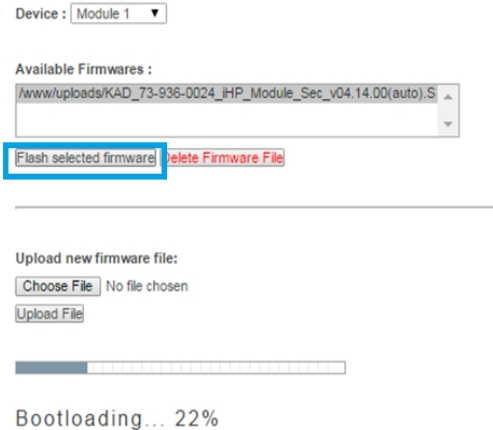

11. The Webtool will notify the user once the bootloading is completed.

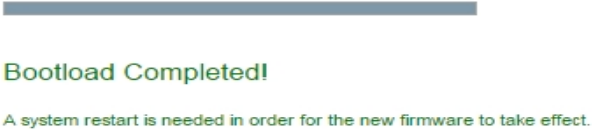

- 12. Turn-off input AC for 10seconds.
- 13. FW update finish.
- 14. Power-up again the input AC for FW version checking.

WebTool

15. Go to WebTool Home page to check the FW version.

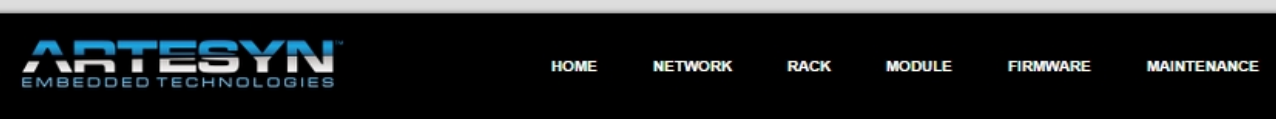

ISOCOMM :

MAC Address :	7C:66:9D:12:B9:94
IP Address :	192.168.2.100
Serial Number :	K835RW0001CCP
Firmware Version:	03.05.01

PFC :

PFC1 Firmware Version:	02.16.00
PFC2 Firmware Version:	02.16.00

Modules :

Module 1:	Model:	73-936-0250
	Firmware Version:	04.14.00
Module 2:	Model:	73-936-0250
	Firmware Version:	04.12.00
Module 3:	Model:	73-936-0250
	Firmware Version:	04.12.00
Module 4:	Model:	73-936-0250
	Firmware Version:	04.12.00

WebTool

Maintenance Section

This section contains the “Reset System” button.

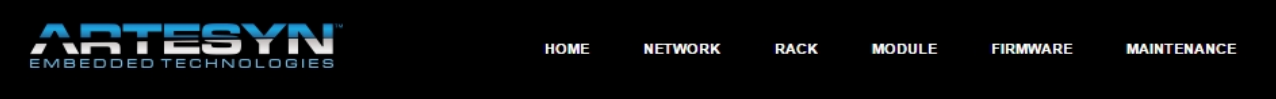

Reset System

Once user press the “Reset System” button, all modules will shutdown. ISOCOMM will re-boot. ISOCOMM boot time is around 21secs. System LED and output LED will be off and power LED will be blinking green. After 20secs, ISOCOMM is now configured to the new setting and operational.

All changes in the configuration in the WebTool will take into effect after AC recycle or reset via pressing the “Reset System” button in the WebTool Maintenance Section.

iHP Series Supported PMBus™ Command List

PFC Supported PMBus™ Command List:

Command Code	Command Name	Default Value (HEX)	Access Type	Data Bytes	Data Format	Description
03h	CLEAR_FAULTS	-	S			Used to remove the warning or fault bits set in the status register
10h	WRITE_PROTECT	00	R/W	1	Bitmapped	Used to enable or disable writing to the module PMBus™ registers 80h - Disables write except 10h 00h - Enables write to all writeable commands
78h	STATUS_BYTE	00	R	1	Bitmapped	Summary of critical faults
	b7 - BUSY	-				Not supported
	b6 - OFF	-				Unit is OFF
	b5 - VOUT_OV_FAULT	-				Output over-voltage fault has occurred
	b4 - IOUT_OC_FAULT	-				Not supported
	b3 - VIN_UV_FAULT	-				An input under-voltage fault has occurred
	b2 - TEMPERATURE	-				A temperature fault or warning has occurred
	b1 - CML	-				A communication, memory or logic fault has occurred
	b0 - NONE OF THE ABOVE	-				Not supported
79h	STATUS_WORD	0000	R	2	Bitmapped	Summary of units fault and warning status
	b15 - VOUT					An output voltage fault or warning has occurred
	b14 - IOUT/POUT					An output-current or power fault or warning has occurred
	b13 - INPUT					An input voltage, current or power fault or warning as occurred
	b12 - MFR					A manufacturer specific fault or warning has occurred
	b11 - POWER_GOOD#					The POWER_GOOD signal is de-asserted
	b10 - FANS					Not supported
	b9 - OTHER					Not supported
	b8 - UNKNOWN					Not supported
	b7 - BUSY					Not supported
	b6 - OFF					Unit is OFF
	b5 - VOUT_OV_FAULT					Output over-voltage fault has occurred
	b4 - IOUT_OC_FAULT					Not supported
	b3 - VIN_UV_FAULT					An input under-voltage fault has occurred
	b2 - TEMPERATURE					A temperature fault or warning has occurred
	b1 - CML					A communication, memory or logic fault has occurred
	B0 - NONE OF THE ABOVE					Not supported

iHP Series Supported PMBus™ Command List

PFC Supported PMBus™ Command List:

Command Code	Command Name	Default Value (HEX)	Access Type	Data Bytes	Data Format	Description
7Ah	STATUS_VOUT	00	R	1	Bitmapped	Output voltage related faults and warnings
	b7					Vout over-voltage fault
	b6					Vout over-voltage warning
	b5					Vout under-voltage warning
	b4					Vout under-voltage fault
	b3:0					Not supported
7Ch	STATUS_INPUT	00	R	1	Bitmapped	Input related faults and warnings
	b7					Vin over-voltage fault
	b6					Vin over-voltage warning
	b5					Vin under-voltage warning
	b4					Vin under-voltage fault
	b3:0					Not supported
7Dh	STATUS_TEMPERATURE	00	R	1	Bitmapped	Temperature related faults and warnings
	b7					Over-temperature fault
	b6					Over-temperature warning
	b5:0					Not supported
7Eh	STATUS_CML	00	R	1	Bitmapped	Communications, logic and memory
	b7					Invalid or unsupported command received
	b6					Invalid or unsupported data received
	b5					Packet error check failed
	b4					Memory fault detect, CRC Error
	b3:0					Not supported
80h	STATUS_MFR_SPECIFIC	00	R	1	Bitmapped	Manufacturer status codes
	b7					RAIL3 fault
	b6					RAIL2 fault
	b5					RAIL1 fault
	b4:1					Not supported
	b0					BULK OVP/DVP
99h	MFR_ID	ARTESYN	BR	7	ASCII	Abbrev or symbol of manufacturers name. ASCII (artesyn)
9Ah	MFR_MODEL		BR	15	ASCII	Manufacturers model number. ASCII format
E0h	FW_PRI_VERSION	-	BR	8	ASCII	The SW version of the device. ASCII format

iHP Series Supported PMBus™ Command List

PFC Supported PMBus™ Command List:

Command Code	Command Name	Default Value (HEX)	Access Type	Data Bytes	Data Format	Description	
E9h	MFR_STATUS_01		BR	6	Bitmapped	This command has 3 indexes. Each index contains 2 bytes of data.	
	Index 00			2	Bitmapped	Input status	
	b15:12					Reserved	
	b11					Vin3 OVP	
	b10					Vin2 OVP	
	b9					Vin1 OVP	
	b8					Vin3 UVP	
	b7					Vin2 UVP	
	b6					Vin1 UVP	
	b5					AUX	
	b4					Relay	
	b3					Supply	
	b2					PSON	
	b1					Address	
	b0					BulkOK	
	Index 01				2	Bitmapped	PFC status
	b15:9						Reserved
	b8						OPW
	b7						OCW
	b6						OVW
	b5						Other
	b4						SCKT
	b3						OCP
	b2						UVP
	b1						OVP
	b0						OutOK
	Index 02				2	Bitmapped	VBUS status
	b15:12						Reserved
	b11						Differential voltage protection rail3
	b10						Differential voltage protection rail2
	b9						Differential voltage protection rail1
	b8						Bulk short circuit3
	b7						Bulk short circuit2
	b6						Bulk short circuit1
	b5						Bulk under-voltage protection rail3
	b4						Bulk under-voltage protection rail2
	b3						Bulk under-voltage protection rail1
	b2						Bulk over-voltage protection rail3
	b1						Bulk over-voltage protection rail2
	b0						Bulk over-voltage protection rail1

iHP Series Supported PMBus™ Command List

Module Supported PMBus™ Command List:

Command Code	Command Name	Default Value (HEX)	Access Type	Data Bytes	Data Format	Description
01h	OPERATION	80	R/W	1	Bitmapped	Used to turn ON/OFF the module
	b7:6					00 - Turn OFF 10 - Turn ON
	b5:0					Reserved
03h	CLEAR_FAULTS	-	S			
10h	WRITE_PROTECT	00	R/W	1	Bitmapped	Used to control writing to the PMBus™ Device. 80h - Disables write except 10h 40h - Disables write except 10h, 01h 00h - Enables write to all writeable commands
24h	VOUT_MAX		BR	3	Direct	Read the max output voltage of the module. Automatically set to 120% of nominal rating. Multiplier is 10000.
31h	POUT_MAX		R	2	Linear	Read Module's rated power.
41h	VOUT_OV_FAULT_RESPONSE	80	R	1	Bitmapped	Read Module Response during over-voltage fault condition. Fix Data: 80h - Device Latch
45h	VOUT_UV_FAULT_RESPONSE	80	R	1	Bitmapped	Read Module Response during under-voltage fault condition. Fix Data: 80h - Device Latch
48h	OV_FAULT_LIMIT_MULTIPLIER	2EE0	BR/BW	2	Direct	Used to compute for the tracking over voltage protection (OVP) of the module. Multiplier is 100. Range: 120% to 130% During Digital Voltage Source (DVS), Analog Current Source (ACS), and Digital Current Source (DCS), OVP Level = VREF + (Nominal Voltage * (OVP Multiplier-1)) During AVS, this PMBus™ Register is not functional.
49h	OV_WARN_LIMIT_MULTIPLIER	2904	BR/BW	2	Direct	Used to compute for the tracking over voltage warning (OVW) of the module. Multiplier is 100. Range: 105% to 125% During Digital Voltage Source (DVS), Analog Current Source (ACS), and Digital Current Source (DCS), OVW Level = VREF + (Nominal Voltage * (OVW Multiplier-1)) During AVS, this PMBus™ Register is not functional.

iHP Series Supported PMBus™ Command List

Module Supported PMBus™ Command List:

Command Code	Command Name	Default Value (HEX)	Access Type	Data Bytes	Data Format	Description
4Bh	UV_FAULT_LIMIT_MULTIPLIER	2134	BR/BW	2	Direct	Used to compute for the tracking under voltage protection (UVP) of the module. Multiplier is 100. Range: 80% to 90% Under Voltage Protection is functional during Digital Programming Voltage Source (DVS) UVP Level = VREF – (Nominal Voltage * (1-UVP Multiplier)) This function will be disabled when the VREF is set to less than or equal to 10% of the nominal.
4Ch	UV_WARN_LIMIT_MULTIPLIER	2328	BR/BW	2	Direct	Used to compute for the tracking under voltage warning (UVW) of the module Multiplier is 100 Range: 85% to 95% Under Voltage Protection is functional during Digital Programming Voltage Source (DVS) UVW Level = VREF – (Nominal Voltage * (1-UVP Multiplier)) This function will be disabled when the VREF is set to less than or equal to 10% of the nominal
4Dh	OC_FAULT_LIMIT_MULTIPLIER	2904	BR/BW	2	Direct	Used to compute for the tracking over current protection (OCP) level of the module Multiplier is 100 Range: 50% to 105% During Digital Voltage Source (DVS) and Analog Voltage Source (AVS), Latch type OC level = (Io nominal)*(OC_FAULT_LIMIT_MULTIPLIER) CC type OC level = (Io nominal)*(OC_FAULT_LIMIT_MULTIPLIER) It is not functional during Digital Current Source and Analog Current Source
4Fh	OT_FAULT_LIMIT		R	2	Linear	Over-temperature protection level of the Module for TEMP1 Fix data varies per module series
50h	OT_FAULT_RESPONSE	B8	R	1	Bitmapped	Read module response during over temperature fault condition Fix Data: B8h - Device Shuts down
51h	OT_WARN_LIMIT		R	2	Linear	Over-temperature warning level of the Module for TEMP1 Fix data varies per module series

iHP Series Supported PMBus™ Command List

Module Supported PMBus™ Command List:

Command Code	Command Name	Default Value (HEX)	Access Type	Data Bytes	Data Format	Description
52h	OC_RESPONSE_TYPE	00	R/W	1	Bitmapped	Command to read/write over-current protection type. Applicable only during Voltage Source configuration
	b7:0					00h - CC Type Protection 01h - Latch Type Protection
5Eh	POWER_GOOD_ON		BR	3	Direct	Read the output voltage level (DVS) where POWER_GOOD signal is asserted Multiplier is 10000 During Digital Programming Voltage Source, Vo@ Power Good On = VREF * POWER_GOOD_ON This command is not functional during DCS, AVS and ACS
5Fh	POWER_GOOD_OFF		BR	3	Direct	Read the output voltage level (DVS) where POWER_GOOD signal is de-asserted Multiplier is 10000 During Digital Programming Voltage Source, Vo@ Power Good Off = VREF * POWER_GOOD_OFF This command is not functional during APVS and APCS
78h	STATUS_BYTE	00	R	1	Bitmapped	Summary of critical faults
	b7 - BUSY	-				Not supported
	b6 - OFF	-				Unit is OFF
	b5 - VOUT_OV_FAULT	-				Output over-voltage fault has occurred
	b4 - IOUT_OC_FAULT	-				Output over-current fault has occurred
	b3 - VIN_UV_FAULT	-				Not supported
	b2 - TEMPERATURE	-				A temperature fault or warning has occurred
	b1 - CML	-				A communication, memory or logic fault has occurred
b0 - NONE OF THE ABOVE	-				A fault warning not listed in bits[7:1] has occurred	

IHP Series Supported PMBus™ Command List

Module Supported PMBus™ Command List:

Command Code	Command Name	Default Value (HEX)	Access Type	Data Bytes	Data Format	Description
79h	STATUS_WORD	0000	R	2	Bitmapped	Summary of units fault and warning status
	b15 - VOUT					An output voltage fault or warning has occurred
	b14 - IOUT/POUT					An output current or power fault or warning has occurred
	b13 - INPUT					An input voltage, current or power fault or warning as occurred
	b12 - MFR_SPECIFIC					A manufacturer specific fault or warning has occurred
	b11 - POWER_GOOD#					The POWER_GOOD signal is de-asserted
	b10:7					Not supported
	b6 - OFF					Unit is OFF
	b5 - VOUT_OV_FAULT					Output over-voltage fault has occurred
	b4 - IOUT_OC_FAULT					Output over-current fault has occurred
	b3 - VIN_UV_FAULT					Not supported
	b2 - TEMPERATURE					A temperature fault or warning has occurred
	b1 - CML					A communication, memory or logic fault has occurred
	b0 - NONE_OF_THE_ABOVE					A fault or warning not listed in bits[7:1] of this byte has occurred
7Ah	STATUS_VOUT	00	R	1	Bitmapped	Output voltage related faults and warnings
	b7					Vout over-voltage fault
	b6					Vout over-voltage warning
	b5					Vout under-voltage warning
	b4					Vout under-voltage fault
	b3:0					Not supported
7Bh	STATUS_IOUT	00	R	1	Bitmapped	Output current related faults and warnings
	b7					Iout over-current fault
	b6					Not supported
	b5					Iout over-current warning
	b4:0					Not supported
7Ch	STATUS_INPUT	00	R	1	Bitmapped	Input related faults and warnings
	b7:3					Not supported
	b2					Iin over-current fault, asserted when module primary over-current fault is triggered
	b1					Iin over-current warning, asserted when module primary over-current fault is triggered
	b0					Not supported

iHP Series Supported PMBus™ Command List

Module Supported PMBus™ Command List:

Command Code	Command Name	Default Value (HEX)	Access Type	Data Bytes	Data Format	Description
7Dh	STATUS_TEMPERATURE	00	R	1	Bitmapped	Temperature related faults and warnings
	b7					Over-temperature fault
	b6					Over-temperature warning
	b5:0					Not supported
7Eh	STATUS_CML	00	R	1	Bitmapped	Communications, logic and memory
	b7					Invalid or unsupported command received
	b6					Invalid or unsupported data received
	b5					Packet error check failed
	b4					Memory fault detect
b3:0					Not supported	
80h	STATUS_MFR_SPECIFIC		R	1	Bitmapped	
	b7					Asserted when memory error occur
	b6					Reserved
	b5					Asserted when DSP supply goes below regulation
	b4					Reserved
	b3					Asserted when module primary current imbalance occur
	b2					Asserted when module primary over-current occur
	b1					Reserved
b0					Asserted when internal CAN communication fault occur	
8Bh	READ_VOUT	-	BR	3	Direct	Returns the actual, measured voltage in Volts Multiplier is 10000
8Ch	READ_IOUT	-	BR	3	Direct	Returns the output current in amperes Multiplier is 10000
8Dh	READ_TEMPERATURE_1	-	R	2	Linear	Module power device temperature reporting
8Fh	READ_TEMPERATURE_3	-	R	2	Linear	Module Transformer temperature reporting
96h	READ_POUT	-	R	2	Linear	Returns the output power, in Watts.
99h	MFR_ID	"ARTESYN"	BR	7	ASCII	Abbrev or symbol of manufacturers name. ASCII (ARTESYN)
9Ah	MFR_MODEL		BR	15	ASCII	Manufacturers model number, ASCII format varies per module series
9Bh	MFR_REVISION		BR	2	ASCII	Manufacturers revision number, ASCII format, varies per module series
9Ch	MFR_LOCATION	"PHILIPPINES"	BR	6	ASCII	Manufacturers facility, ASCII format Fix data: "PHILIPPINES"
9Dh	MFR_DATE		BR	2	ASCII	Manufacture Date, ASCII format Data format: "YYMMDD"
9Eh	MFR_SERIAL		BR	13	ASCII	Unit serial number, ASCII format

iHP Series Supported PMBus™ Command List

Module Supported PMBus™ Command List:

Command Code	Command Name	Default Value (HEX)	Access Type	Data Bytes	Data Format	Description
A4h	MFR_VOUT_MIN		BR	3	Direct	Minimum output voltage that can be set in the module Multiplier is 10000
A5h	MFR_VOUT_MAX		BR	3	Direct	Maximum output voltage that can be set in the module Multiplier is 10000
A6h	MFR_IOUT_MAX		BR	3	Direct	Maximum output current that can be set in the module Multiplier is 10000
A7h	MFR_POOUT_MAX		R	2	Linear	Maximum output power that can be delivery by the module
B0h	FRU_DATA		BR		Varies	Return to FRU data of the Module in ASCII.
B1h	VREF		BR/BW	3	Direct	Module voltage reference. Command have different function in each Module operation (D3h) Multiplier is 10000 1. Digital Voltage Source User can change output voltage using this command from 5% of nominal Vout to 120% of nominal Vout. The module will enter to standby mode when user writes 0V to this register. 2. Analog Voltage Source Read Only. Not functional during this operation Automatically set to module nominal output voltage 3. Digital/Analog Current Source User can change output voltage using this command from 5% of nominal Vout to 100% of nominal Vout Clamp voltage during Current Source operation

iHP Series Supported PMBus™ Command List

Module Supported PMBus™ Command List:

Command Code	Command Name	Default Value (HEX)	Access Type	Data Bytes	Data Format	Description
B2h	IREF		BR/BW	3	Direct	<p>Module current reference Multiplier is 10000</p> <p>1. Digital Current Source User can change output current using this command from 0A to nominal output current The module will enter to standby mode when user writes 0A to this register.</p> <p>2. Analog Current Source Read Only. Not functional during this operation. Automatically set to 0A.</p> <p>3. Digital/Analog Voltage Source Read only. Latch type fault: Fix to 120% of nominal output current. Not functional. CC Type Fault: IREF= (Io nominal)*(OC_FAULT_LIMIT_MULTIPLIER) PMBus™ command 4Dh OC_FAULT_LIMIT_MULTIPLIER</p>
B5h	SET_VOLTAGE_RISE_SETTING		BR	2	Direct	<p>Read the voltage rise time during Module's Digital Voltage Source (DVS) operation Multiplier is 1 Data Range: 00h - 0Fh</p>
	Byte1:Byte2					<p>The module rise time setting</p> <p>0x00h - 10mS (+/-5mS) 0x01h - 20mS (+/-5mS) 0x02h - 50mS (+/-5mS) 0x03h - 70mS (+/-5mS) 0x04h - 80mS (+/-5mS) 0x05h - 90mS (+/-5mS) 0x06h - 100mS (+/-5mS) 0x07h - 110mS (+/-5mS) 0x08h - 120mS (+/-5mS) 0x09h - 130mS (+/-5mS) 0x0Ah - 140mS (+/-5mS) 0x0Bh - 150mS (+/-5mS) 0x0Ch - 175mS (+/-10mS) 0x0Dh - 200mS (+/-10mS) 0x0Eh - 225mS (+/-10mS) 0x0Fh - 250mS (+/-10mS)</p>

iHP Series Supported PMBus™ Command List

Module Supported PMBus™ Command List:

Command Code	Command Name	Default Value (HEX)	Access Type	Data Bytes	Data Format	Description
B6h	SET_CURRENT_RISE_SETTING	0000	BR	2	Direct	Read the current rise time during Module's Digital Current Source (DCS) operation Multiplier is 1 Data Range: 00h - 0Fh
	Byte1:Byte2					The module rise time setting 0x00h - 7.2mS 0x01h - 100mS (+/-10mS) 0x02h - 125mS (+/-10mS) 0x03h - 150mS (+/-10mS) 0x04h - 175mS (+/-10mS) 0x05h - 200mS (+/-10mS) 0x06h - 225mS (+/-10mS) 0x07h - 250mS (+/-10mS) 0x08h - 300mS (+/-10mS) 0x09h - 350mS (+/-10mS) 0x0Ah - 400mS (+/-10mS) 0x0Bh - 450mS (+/-10mS) 0x0Ch - 500mS (+/-10mS) 0x0Dh - 700mS (+/-50mS) 0x0Eh - 900mS (+/-50mS) 0x0Fh - 1250mS (+/-50mS)
B7h	SET_IO_ACTIVE_LEVEL_LOGIC	0001	BR/BW	2	Bitmapped	Set the logic of SYS_M_FAULT#, SYS_M_ENABLE#, and SYS_M_INHIBIT signals
	b15:8					Fixed 00
	b7:3					Reserved
	b2					1 - SYS_M_FAULT# Logic High means Module is at Fault 0 - SYS_M_FAULT# Logic Low means Module is at Fault
	b1					1 - Module will turn-off if SYS_M_INHIBIT is Logic High 0 - Module will turn-off if SYS_M_INHIBIT is Logic Low
	b0					1 - Module will turn-on if SYS_M_ENABLE# is Logic High 0 - Module will turn-on if SYS_M_ENABLE# is Logic Low
B8h	SET_MODULE_LOAD TYPE	0002	BR	2	Bitmapped	Read Module compensation 01h - Resistive load compensation 02h - Capacitive load compensation 04h - LED load compensation

iHP Series Supported PMBus™ Command List

Module Supported PMBus™ Command List:

Command Code	Command Name	Default Value (HEX)	Access Type	Data Bytes	Data Format	Description
BAh	ANALOG_FILTER_ENABLE	00	R/W	1	Bitmapped	To enable or disable heavy filtering of IPROG signal during ACS or VPROG signal during AVS
	b7:2					Reserved
	b1					1 - ACS heavy filter enabled 0 - ACS heavy filter disabled
	b0					1 - AVS operation and modules in parallel. Sharing enable 0 - AVS operation and modules stand-alone Waveshape enable
D0h	SHUTDOWN_CAUSE		R	1	Bitmapped	Indicate the cause of Module shutdown
	b7:4					Reserved
	b3					Config inhibit status: module inhibit status during module configuration change
	b2					1 - Module is OFF 0 - Module is ON
	b1					Module auto recoverable fault assert bit due to: 1) OT fault 2) COMM fault 3) Invalid programming (PGM) range 4) Output short circuit
	b0					Module latch type fault assert bit due to: 1) Over-voltage fault 2) Under-voltage fault 3) Over-current fault 4) Primary over-current fault 5) Rail imbalance fault 6) Supply_MON fault
D3h	MODULE_CONFIG	00	R	1	Bitmapped	Read module configuration mode
	b7:4					Reserved
	b3 - Source Selection					1 - Current Source Mode 0 - Voltage Source Mode
	b2					Reserved
	b1 - Select Analog or Digital Control					1 - Analog Control 0 - Digital Control
	b0 - Current Sensing					1 - External Shunt 0 - Internal Shunt

iHP Series Supported PMBus™ Command List

Module Supported PMBus™ Command List:

Command Code	Command Name	Default Value (HEX)	Access Type	Data Bytes	Data Format	Description
D8h	VPROG_LOW_LIMIT					Returns the actual percentage of the VREF value that Vprog low limit protection will taken effect. Used to change the Vprog low limit level. The value is a percentage of the VREF. Valid range is from 5% to 50%. Writing 0 disables the protection. If the PSU is in standby mode, all written data except 0 will considered invalid.
D9h	iPROG_LOW_LIMIT					Returns the actual percentage of the IREF value that Iprog low limit protection will taken effect. Used to change the Iprog low limit level. The value is a percentage of the IREF. Valid range is from 5% to 50%. Writing 0 disables the protection. If the PSU is in standby mode, all written data except 0 will considered invalid.
DAh	VREF_MAX_LIMIT					Returns the actual value VREF maximum limit used for command B1h VREF_TRIM. Used to change the VREF maximum limit used for command B1h VREF_TRIM. Valid range varies per model.
DBh	IREF_MAX_LIMIT					Returns the actual value IREF maximum limit used for command B2h IREF_TRIM. Used to change the IREF maximum limit used for command B2h IREF_TRIM. Valid range varies per model and also depends on maximum Pout when Vout is above the nominal value.
E1h	FW_SEC_VERSION	-	BR	8	ASCII	Read module software version
E5h	OPTN_TIME_TOTAL		BR	4	Direct	Read the total time when the module is turn-on and the output is operational This will reset when the iHP Rack is turn-off. Multiplier is 1
E6h	OPTN_TIME_PRESENT		BR	4	Direct	Read the total time when the module is turn-on and the output is operational This will reset when the module enters to standby mode Multiplier is 1
E8h	HISTORY_CLEAR		S			Clear history data
E9h	CALIBRATION_DATE		BR	6	ASCII	Read the last calibration date Data representation: YYMMDD YY - Year, MM - Month, DD - Day

iHP Series Supported PMBus™ Command List

ISOCOMM Supported PMBus™ Command List:

Command Code	Command Name	Default Value (HEX)	Access Type	Data Bytes	Data Format	Description
01h	OPERATION	80	R/W	1	Bitmapped	Used to turn ON/OFF all modules
	b7					0 - Turn OFF 1 - Turn ON
	b6:0					Reserved
03h	CLEAR_FAULTS	-	S			
10h	WRITE_PROTECT	00	R/W	1	Bitmapped	Used to control writing to the PMBus™ device 80h - Disables write except 10h 00h - Enables write to all writeable commands
3Ah	FAN_CONFIG_1_2	99	R	1	Bitmapped	Read only to reflect setting of Fans
	b7	1				1 - Fan1 is present 0 - Fan1 is not present
	b6	0				1 - Fan1 is commanded in RPM 0 - Fan1 is commanded in Duty Cycle
	b5:4	01				Fan1 tachometer pulses per revolution 00 - 1 pulse per revolution 01 - 2 pulse per revolution 10 - 3 pulse per revolution 11 - 4 pulse per revolution
	b3	1				1 - Fan2 is present 0 - Fan2 is not present
	b2	0				1 - Fan2 is commanded in RPM 0 - Fan2 is commanded in Duty Cycle
	b1:0	01				Fan2 tachometer pulses per revolution 00 - 1 pulse per revolution 01 - 2 pulses per revolution 10 - 3 pulses per revolution 11 - 4 pulses per revolution
3Dh	FAN_CONFIG_3_4	99	R	1	Bitmapped	Read only to reflect setting of Fans
	b7	1				1 - Fan3 is present 0 - Fan3 is not present
	b6	0				1 - Fan3 is commanded in RPM 0 - Fan3 is commanded in Duty Cycle
	b5:4	01				Fan3 tachometer pulses per revolution 00 - 1 pulse per revolution 01 - 2 pulse per revolution 10 - 3 pulse per revolution 11 - 4 pulse per revolution
	b3	1				1 - Fan4 is present 0 - Fan4 is not present
	b2	0				1 - Fan4 is commanded in RPM 0 - Fan4 is commanded in Duty Cycle
	b1:0	01				Fan4 tachometer pulses per revolution 00 - 1 pulse per revolution 01 - 2 pulses per revolution 10 - 3 pulses per revolution 11 - 4 pulses per revolution

iHP Series Supported PMBus™ Command List

ISOCOMM Supported PMBus™ Command List:

Command Code	Command Name	Default Value (HEX)	Access Type	Data Bytes	Data Format	Description
78h	STATUS_BYTE	00	R	1	Bitmapped	Returns the summary of critical faults
	b7:3	-				Not supported
	b2 - TEMPERATURE	-				A temperature fault or warning has occurred
	b1 - CML	-				A communication, memory or logic fault has occurred
	b0 - NONE OF THE ABOVE	-				A fault warning not listed in bits[7:1] has occurred
79h	STATUS_WORD	0000	R	2	Bitmapped	Summary of units fault and warning status
	b15:13					Not supported
	b12 - MFR_SPECIFIC					A manufacturer specific fault or warning has occurred
	b11 - POWER_GOOD#					Not supported
	b10 - FANS					A fan or airflow fault or warning has occurred
	b9:3					Not supported
	b2 - TEMPERATURE					A temperature fault or warning has occurred
	b1 - CML					A communication, memory or logic fault has occurred
b0 - NONE_OF_THE_ABOVE					A fault or warning not listed in bits[7:1] of this byte has occurred	
7Dh	STATUS_TEMPERATURE	00	R	1	Bitmapped	Temperature related faults and warnings
	b7					Over-temperature fault
	b6					Over-temperature warning
	b5:0					Not supported
7Eh	STATUS_CML	00	R	1	Bitmapped	Communications, logic and memory
	b7					Invalid or unsupported command received
	b6					Invalid or unsupported data received
b5:0					Not supported	
80h	STATUS_MFR	0000	R	2	Bitmapped	Manufacturer status codes
	b15					RAIL3 fault
	b14					RAIL2 fault
	b13					RAIL1 fault
	b12:9					Not supported
	b8					BULK OVP/DVP
	b7:6					Not supported
	b5					Rack SYNC Off
	b4					GROUP mismatched
	b3					Module communication error
	b2					PFC communication error
	b1					Module synchronize OFF
b0					5V standby error	

iHP Series Supported PMBus™ Command List

ISOCOMM Supported PMBus™ Command List:

Command Code	Command Name	Default Value (HEX)	Access Type	Data Bytes	Data Format	Description
81h	STATUS_FANS_1_2	00	R	1	Bitmapped	
	b7					Fan1 fault
	b6					Fan2 fault
	b5:0					Not supported
82h	STATUS_FANS_3_4	00	R	1	Bitmapped	
	b7					Fan3 fault
	b6					Fan4 fault
	b5:0					Not supported
8Dh	READ_TEMPERATURE_1	-	R	2	Linear	The highest temperature between PFC1 and PFC2
8Eh	READ_TEMPERATURE_2	-	R	2	Linear	The internal ambient temperature of the iHP Rack. Temperature sensor of the internal ambient temperature is located on the front panel.
90h	READ_FAN1_SPEED	-	R	2	Linear	iHP RACK fan1 speed reporting in RPM
91h	READ_FAN2_SPEED	-	R	2	Linear	iHP RACK fan2 speed reporting in RPM
92h	READ_FAN3_SPEED	-	R	2	Linear	iHP RACK fan3 speed reporting in RPM
93h	READ_FAN4_SPEED	-	R	2	Linear	iHP RACK fan4 speed reporting in RPM
99h	MFR_ID	ARTESYN	BR	7	ASCII	Abbrev or symbol of manufacturers name ASCII (ARTESYN)
9Ah	MFR_MODEL		BR	12	ASCII	Manufacturers model number, ASCII format
9Bh	MFR_REVISION		BR	2	ASCII	Manufacturers revision number, ASCII format
9Ch	MFR_LOCATION	PHILIPPINES	BR	1	ASCII	Manufacturers facility, ASCII format
9Dh	MFR_DATE		BR	2	ASCII	Manufacture date, ASCII format Data format: "YYMMDD"
9Eh	MFR_SERIAL		BR	13	ASCII	Rack serial number, ASCII format
B0h	FRU_DATA	-	BR	256	ASCII	FRU data of the ISOCOMM

iHP Series Supported PMBus™ Command List

ISOCOMM Supported PMBus™ Command List:

Command Code	Command Name	Default Value (HEX)	Access Type	Data Bytes	Data Format	Description
B5h	MODULE_VRISE_TIME		BW	4	Bitmapped	Set the voltage rise time of the module during Module's Digital Programming Voltage Source (DPVS) operation After sending this PMBus™ command, all modules will shut down and restart again
	Byte1	03				Indicates the byte count or "03"
	Byte2					The module slot or group number in which the setting will be implemented 00 - Slot1 module 01 - Slot2 module 02 - Slot3 module 03 - Slot4 module 04 - Slot5 module 05 - Slot6 module 06 - Slot7 module 07 - Slot8 module 08 - Group1 module 09 - Group2 module 0A - Group3 module 0B - Group4 module 0C - Group5 module 0D - Group6 module 0E - Group7 module
	Byte3:Byte4					The module rise time setting. 00 00 - 10mS (+/-5mS) 01 00 - 20mS (+/-5mS) 02 00 - 50mS (+/-5mS) 03 00 - 70mS (+/-5mS) 04 00 - 80mS (+/-5mS) 05 00 - 90mS (+/-5mS) 06 00 - 100mS (+/-5mS) 07 00 - 110mS (+/-5mS) 08 00 - 120mS (+/-5mS) 09 00 - 130mS (+/-5mS) 0A 00 - 140mS (+/-5mS) 0B 00 - 150mS (+/-5mS) 0C 00 - 175mS (+/-10mS) 0D 00 - 200mS (+/-10mS) 0E 00 - 225mS (+/-10mS) 0F 00 - 250mS (+/-10mS)

iHP Series Supported PMBus™ Command List

ISOCOMM Supported PMBus™ Command List:

Command Code	Command Name	Default Value (HEX)	Access Type	Data Bytes	Data Format	Description
B6h	MODULE_IRISE_TIME		BW	4	Bitmapped	Set the current rise time of the module during Module's Digital Programming Current Source (DPCS) operation.
	Byte1	03				Indicates the byte count or "03"
	Byte2					The module Slot or Group number in which the setting will be implemented 00 - Slot1 module 01 - Slot2 module 02 - Slot3 module 03 - Slot4 module 04 - Slot5 module 05 - Slot6 module 06 - Slot7 module 07 - Slot8 module 08 - Group1 module 09 - Group2 module 0A - Group3 module 0B - Group4 module 0C - Group5 module 0D - Group6 module 0E - Group7 module
	Byte3:Byte4					The module rise time setting. 00 00 - 7.2mS 01 00 - 100mS (+/-10mS) 02 00 - 125mS (+/-10mS) 03 00 - 150mS (+/-10mS) 04 00 - 175mS (+/-10mS) 05 00 - 200mS (+/-10mS) 06 00 - 225mS (+/-10mS) 07 00 - 250mS (+/-10mS) 08 00 - 300mS (+/-10mS) 09 00 - 350mS (+/-10mS) 0A 00 - 400mS (+/-10mS) 0B 00 - 450mS (+/-10mS) 0C 00 - 500mS (+/-10mS) 0D 00 - 700mS (+/-50mS) 0E 00 - 900mS (+/-50mS) 0F 00 - 1250mS (+/-50mS)

iHP Series Supported PMBus™ Command List

ISOCOMM Supported PMBus™ Command List:

Command Code	Command Name	Default Value (HEX)	Access Type	Data Bytes	Data Format	Description
B8h	MODULE_LOAD_TYPE		BW	4	Bitmapped	Set the load type of the module.
	Byte1	03				Indicates the byte count or "03"
	Byte2					The module Slot or Group number in which the setting will be implemented 00 - Slot1 module 01 - Slot2 module 02 - Slot3 module 03 - Slot4 module 04 - Slot5 module 05 - Slot6 module 06 - Slot7 module 07 - Slot8 module 08 - Group1 module 09 - Group2 module 0A - Group3 module 0B - Group4 module 0C - Group5 module 0D - Group6 module 0E - Group7 module
	Byte3:Byte4					The load type setting. 01 00 - Resistive 02 00 - Capacitive 04 00 - LED
CAh	READ_VIN1		R	2	Direct	iHP RACK Input Voltage reporting (Vac) for Line1 Multiplier is 10
CBh	READ_VIN2		R	2	Direct	iHP RACK Input Voltage reporting (Vac) for Line2 Multiplier is 10
CCh	READ_VIN3		R	2	Direct	iHP RACK Input Voltage reporting (Vac) for Line3 Multiplier is 10
CDh	READ_IIN1		R	2	Direct	iHP RACK Input Current reporting (Vac) for Line1 Multiplier is 100
CEh	READ_IIN2		R	2	Direct	iHP RACK Input Current reporting (Vac) for Line2 Multiplier is 100
CFh	READ_IIN3		R	2	Direct	iHP RACK Input Current reporting (Vac) for Line3 Multiplier is 100

iHP Series Supported PMBus™ Command List

ISOCOMM Supported PMBus™ Command List:

Command Code	Command Name	Default Value (HEX)	Access Type	Data Bytes	Data Format	Description
D3h	MODULE_CONFIG		W	2	Bitmapped	Set the module configuration. After sending this PMBus™ command, all modules will shut down and restart again
	Byte1					The module Slot or Group number in which the setting will be implemented 00 - Slot1 module 01 - Slot2 module 02 - Slot3 module 03 - Slot4 module 04 - Slot5 module 05 - Slot6 module 06 - Slot7 module 07 - Slot8 module 08 - Group1 module 09 - Group2 module 0A - Group3 module 0B - Group4 module 0C - Group5 module 0D - Group6 module 0E - Group7 module
	b7:4					Reserved/Unused
	b3 - Source Selection					1 - Current Source Mode 0 - Voltage Source Mode
	b2					Reserved/Unused
	b1 - Select Analog or Digital Control					1 - Analog Control 0 - Digital Control
	b0 - Current Sensing					1 - External Shunt 0 - Internal Shunt
D6h	MODULE_DETECTION		R	1	Bitmapped	Indicate module present in the iHP rack
	b7					Asserted when module is present in slot8
	b6					Asserted when module is present in slot7
	b5					Asserted when module is present in slot6
	b4					Asserted when module is present in slot5
	b3					Asserted when module is present in slot4
	b2					Asserted when module is present in slot3
	b1					Asserted when module is present in slot2
	b0					Asserted when module is present in slot1

iHP Series Supported PMBus™ Command List

ISOCOMM Supported PMBus™ Command List:

Command Code	Command Name	Default Value (HEX)	Access Type	Data Bytes	Data Format	Description
D7h	MODULE_SAVE		W	1	Bitmapped	Indicates the module slot or group number in which the command used to save below module configuration: 48h, 49h, 4Bh, 4Ch, 4Dh, 4Eh, 52h, 53h, 54h, B4h B5h, B6h, B7h, B9h, BAh, D3h, F9h, FAh After sending this PMBus™ command, all modules will shut down and restart again
	Byte1					00 - Slot1 module 01 - Slot2 module 02 - Slot3 module 03 - Slot4 module 04 - Slot5 module 05 - Slot6 module 06 - Slot7 module 07 - Slot8 module 08 - Group1 module 09 - Group2 module 0A - Group3 module 0B - Group4 module 0C - Group5 module 0D - Group6 module 0E - Group7 module
DFh	GROUP_CONFIG		R	8	Bitmapped	The group configuration of the rack The first byte is the length of the data (which also happens to be the number of groups available) 2nd byte = GROUP1, 3rd byte = GROUP2, ... 8th byte = GROUP7. Each byte is bitmapped (Bit0 = Module1, Bit1 = Module2, ...Bit7 = Module8) Asserted bits are the modules which belong to that group
E1h	FW_VERSION	-	R	8	ASCII	Indicate the software version of the ISOCOMM

iHP Series Supported PMBus™ Command List

Group Supported PMBus™ Command List:

Command Code	Command Name	Default Value (HEX)	Access Type	Data Bytes	Data Format	Description
01h	OPERATION	80	R/W	1	Bitmapped	Used to turn ON/OFF all modules.
	b7					0 - Turn OFF 1 - Turn ON
	b6:0					Reserved
03h	CLEAR_FAULTS	-	S			
10h	WRITE_PROTECT	00	R/W	1	Bitmapped	Used to control writing to the PMBus™ device 80h - Disables write except 10h 00h - Enables write to all writeable commands.
48h	OV_FAULT_LIMIT_MULTIPLIER		BR/BW	2	Direct	Used to compute for the tracking over voltage protection (OVP) of the module. Multiplier is 100. Range: 120% to 130% During Digital Voltage Source (DVS), Analog Current Source (ACS), and Digital Current Source (DCS), OVP Level = VREF + (Nominal Voltage * (OVP Multiplier-1)) During AVS, this PMBus™ Register is not functional
49h	OV_WARN_LIMIT_MULTIPLIER		BR/BW	2	Direct	Used to compute for the tracking over voltage warning (OVW) of the module. Multiplier is 100. Range: 105% to 125% During Digital Voltage Source (DVS), Analog Current Source (ACS), and Digital Current Source (DCS), OVW Level = VREF + (Nominal Voltage * (OVP Multiplier-1)) During AVS, this PMBus™ Register is not functional
4Bh	UV_FAULT_LIMIT_MULTIPLIER		BR/BW	2	Direct	Used to compute for the tracking under voltage protection (UVP) of the module. Multiplier is 100. Range: 80% to 90% Under Voltage Protection is functional during Digital Programming Voltage Source (DVS) UVP Level = VREF - (Nominal Voltage * (1-UVP Multiplier)) This function will be disable when the VREF is set to less than or equal to 10% of the nominal

iHP Series Supported PMBus™ Command List

Group Supported PMBus™ Command List:

Command Code	Command Name	Default Value (HEX)	Access Type	Data Bytes	Data Format	Description
4Ch	UV_WARN_LIMIT_MULTIPLIER		BR/BW	2	Direct	Used to compute for the tracking under voltage warning (UVW) of the module. Multiplier is 100. Range: 85% to 95% Under Voltage Protection is functional during Digital Programming Voltage Source (DVS) UVW Level = VREF – (Nominal Voltage * (1-UVP Multiplier)) This function will be disable when the VREF is set to less than or equal to 10% of the nominal.
4Dh	OC_FAULT_LIMIT_MULTIPLIER		BR/BW	2	Direct	Used to compute for the tracking over current protection (OCP) level of the module. Multiplier is 100. Range: 50% to 105% During Digital Voltage Source (DVS) and Analog Voltage Source (AVS), Latch type OC level = (Io nominal)*(OC_FAULT_LIMIT_MULTIPLIER) CC type OC level = (Io nominal)*(OC_FAULT_LIMIT_MULTIPLIER) It is not functional during Digital Current Source and Analog Current Source
52h	OC_RESPONSE_TYPE		R/W	1	Bitmapped	Command to read/write over-current protection type. Applicable only during Voltage Source configuration
	b7:0					00h - CC Type Protection 01h - Latch Type Protection
78h	STATUS_BYTE	00	R	1	Bitmapped	Returns the summary of critical faults
	b7:3	-				Not supported
	b2 - TEMPERATURE	-				A temperature fault or warning has occurred
	b1 - CML	-				A communication, memory or logic fault has occurred
	b0 - NONE OF THE ABOVE	-				A fault warning not listed in bits[7:1] has occurred

iHP Series Supported PMBus™ Command List

Group Supported PMBus™ Command List:

Command Code	Command Name	Default Value (HEX)	Access Type	Data Bytes	Data Format	Description
79h	STATUS_WORD	0000	R	2	Bitmapped	Summary of units fault and warning status.
	b15:13					Not supported
	b12 - MFR					A manufacturer specific fault or warning has occurred
	b11 - POWER_GOOD#					Not supported
	b10 - FANS					A fan or airflow fault or warning has occurred
	b9:3					Not supported
	b2 - TEMPERATURE					A temperature fault or warning has occurred
	b1 - CML					A communication, memory or logic fault has occurred
b0 - NONE_OF_THE_ABOVE					A fault or warning not listed in bits[7:1] of this byte has occurred	
7Ah	STATUS_VOUT	00	R	1	Bitmapped	Output voltage related faults and warnings
	b7					Vout over-voltage fault
	b6					Vout over-voltage warning
	b5					Vout under-voltage warning
	b4					Vout under-voltage fault
	b3:0					Not supported
7Bh	STATUS_IOUT	00	R	1	Bitmapped	Output current related faults and warnings
	b7					Iout over-current Fault
	b6					Iout over-current and low voltage shutdown fault. Not supported
	b5					Iout over-current warning
	b4:0					Not supported
7Ch	STATUS_INPUT	00	R	1	Bitmapped	Input related faults and warnings
	b7:3					Not supported
	b2					Iin over-current fault. Asserted when module primary over-current fault is triggered.
	b1					Iin over-current warning. Asserted when module primary over-current fault is triggered
	b0					Not supported
7Dh	STATUS_TEMPERATURE	00	R	1	Bitmapped	Temperature related faults and warnings
	b7					Over-temperature fault
	b6					Over-temperature warning
	b5:0					Not supported

iHP Series Supported PMBus™ Command List

Group Supported PMBus™ Command List:

Command Code	Command Name	Default Value (HEX)	Access Type	Data Bytes	Data Format	Description
7Eh	STATUS_CML	00	R	1	Bitmapped	Communications, logic and memory
	b7					Invalid or unsupported command received
	b6					Invalid or unsupported data received
	b5					Packet error check failed
	b4					Memory fault detect
	b3:0					Not Supported
80h	STATUS_MFR_SPECIFIC		R	1	Bitmapped	
	b7					Asserted when memory error occur
	b6					Reserved
	b5					Asserted when DSP supply goes below regulation
	b4					Reserved
	b3					Asserted when module primary current imbalance occur
	b2					Asserted when module primary over-current occur
	b1					Reserved
8Bh	READ_VOUT	-	R	2	Direct	Returns the actual, measured voltage in Volts and depends if Parallel or series Parallel: average of all module Vout Series: add all Module Vout
	READ_IOUT	-	R	2	Direct	Returns the output current in amperes and depends if Parallel or series Parallel: add all Module Iout Series: average of all module Iout
8Dh	READ_TEMPERATURE_1	-	R	2	Linear	Hottest temperature of the module in a group
96h	READ_POUT	-	R	2	Linear	Returns the output power of all modules, in Watts

iHP Series Supported PMBus™ Command List

Group Supported PMBus™ Command List:

Command Code	Command Name	Default Value (HEX)	Access Type	Data Bytes	Data Format	Description
B1h	VREF		R/W	3	Direct	<p>Module voltage reference. Command have different function in each module operation (D3h) Multiplier is 10000.</p> <ol style="list-style-type: none"> 1. Digital Voltage Source User can change output voltage using this command from 5% of nominal Vout to 120% of nominal Vout. The module will enter to standby mode when user writes 0V to this register. 2. Analog Voltage Source Read Only. Not functional during this operation. Automatically set to module nominal output voltage. 3. Digital/Analog Current Source User can change output voltage using this command from 5% of nominal Vout to 100% of nominal Vout. Clamp Voltage during Current Source operation
B2h	IREF		R/W	3	Direct	<p>Module current reference. Multiplier is 10000</p> <ol style="list-style-type: none"> 1. Digital Current Source User can change output current using this command from 0A to Nominal output current. The Module will enter to standby mode when user writes 0A to this register. 2. Analog Current Source Read Only Automatically set to 0A. Not functional during this operation. 3. Digital/Analog Voltage Source Read only. Latch type Fault: Fix to 120% of nominal output current. Not functional. CC Type Fault: IREF= (Io nominal)*(OC_FAULT_LIMIT_MULTIPLIER) PMBus™ command 4Dh OC_FAULT_LIMIT_MULTIPLIER

iHP Series Supported PMBus™ Command List

Group Supported PMBus™ Command List:

Command Code	Command Name	Default Value (HEX)	Access Type	Data Bytes	Data Format	Description
B5h	SET_VOLTAGE_RISE_SETTING		BR	2	Direct	Read the voltage rise time during module's Digital Voltage Source (DVS) operation. Multiplier is 1 Data Range: 00h - 0Fh
	Byte1:Byte2					The module rise time setting. 00 02 - 50mS (+/-5mS) 00 03 - 70mS (+/-5mS) 00 04 - 80mS (+/-5mS) 00 05 - 90mS (+/-5mS) 00 06 - 100mS (+/-5mS) 00 07 - 110mS (+/-5mS) 00 08 - 120mS (+/-5mS) 00 09 - 130mS (+/-5mS) 00 0A - 140mS (+/-5mS) 00 0B - 150mS (+/-5mS) 00 0C - 175mS (+/-10mS) 00 0D - 200mS (+/-10mS) 00 0E - 225mS (+/-10mS) 00 0F - 250mS (+/-10mS)
B6h	SET_CURRENT_RISE_SETTING		BR	2	Direct	Read the current rise time during module's Digital Current Source (DVS) operation. Multiplier is 1 Data Range: 00h - 0Fh
	Byte1:Byte2					The module rise time setting. 00 00 - 7.2mS 00 01 - 100mS (+/-10mS) 00 02 - 125mS (+/-10mS) 00 03 - 150mS (+/-10mS) 00 04 - 175mS (+/-10mS) 00 05 - 200mS (+/-10mS) 00 06 - 225mS (+/-10mS) 00 07 - 250mS (+/-10mS) 00 08 - 300mS (+/-10mS) 00 09 - 350mS (+/-10mS) 00 0A - 400mS (+/-10mS) 00 0B - 450mS (+/-10mS) 00 0C - 500mS (+/-10mS) 00 0D - 700mS (+/-50mS) 00 0E - 900mS (+/-50mS) 00 0F - 1250mS (+/-50mS)

iHP Series Supported PMBus™ Command List

Group Supported PMBus™ Command List:

Command Code	Command Name	Default Value (HEX)	Access Type	Data Bytes	Data Format	Description
D3h	MODULE_CONFIG		R/W	1	Bitmapped	Read module configuration mode
	b7:4					Reserved
	b3 - Source Selection					1 - Current Source Mode 0 - Voltage Source Mode
	b2					Reserved
	b1 - Select Analog or Digital Control					1 - Analog Control 0 - Analog Control
	b0 - Current Sensing					1 - External Shunt 0 - Internal Shunt
D4h	MODULE_OPERATION		R/W	1	Bitmapped	00 - Disable Module Operation change 01 - Enable Module Operation change

iHP Series Supported PMBus™ Command List

Data Format: Linear

Data Format “Linear” is one of the PMBus™ Data Format used in iHP units.

Linear data format follows the equation: $X = Y \times 2^N$

Where: X = real world data

Y = transmitted value / mantissa

N = exponent

Convert Linear Data Format to Real World Data

The following steps show how to convert from linear data format to its corresponding real world data:

1. Convert data from hexadecimal format to binary format.

Ex. Linear Data Format in Hex = 1AEE hex

Linear Data Format in Binary = 0001101011101110₂

2. Separate the exponent N from the mantissa Y.

Ex. Linear Data Format in Binary = 0001101011101110₂

The format is aaaaaBBBBBBBBBBB

Where: a is binary format of exponent N = 00011₂

B is binary format of mantissa Y = 01011101110₂

3. Convert exponent N from binary format to its corresponding decimal format.

Ex. N = 00011₂

N = 3

4. Convert mantissa Y from binary format to its corresponding decimal format.

Ex. Y = 01011101110₂

Y = 750

5. Solve for the real world data X using below equation.

$$X = Y \times 2^N$$

$$= 750 \times 2^3$$

$$= 6000$$

iHP Series Supported PMBus™ Command List

Data Format: Direct

Data Format Direct is one of the PMBus™ Data Format used in iHP units. In order to convert the data in to “real word” value, user needs to determine the # of bytes and the multiplier.

The relationship between Y, N, and the “real word” value is: $Y = X \times N$

Where: X is the real word value

Y is the data read from the device in decimal.

N is a the multiplier

Example 1: Module PMBus™ Command 8Bh (READ_VOUT)

of byte = 3 Byte

Multiplier = N = 10000

PMBus™ command 8Bh returns a data of 0757B0h

Convert 0757B0h to decimal = 481200

$Y = X \times N$

$481200 = X \times 10000$

$X = 48.12V$

Example 2: Module PMBus™ Command 8Ch (READ_IOUT)

of byte = 3 Byte

Multiplier = N = 10000

PMBus™ command 8Ch returns a data of 098968h

Convert 098968h to decimal = 625000

$Y = X \times N$

$625000 = X \times 10000$

$X = 62.5A$

Communication Interface Support - Optional EtherCAT

iHP RACK Communication Interface - EtherCAT Option

There're three types of rack communication connectors on the optional ISOCOMM board.

iHP RACK Port	Connector	Functions
J1672	8Pin RJ45	ECAT IN/ECAT OUT
J1522/J1520	Dual RJ9	RS485/CAN Port
TTL	Dsub-9	Provide logic signals

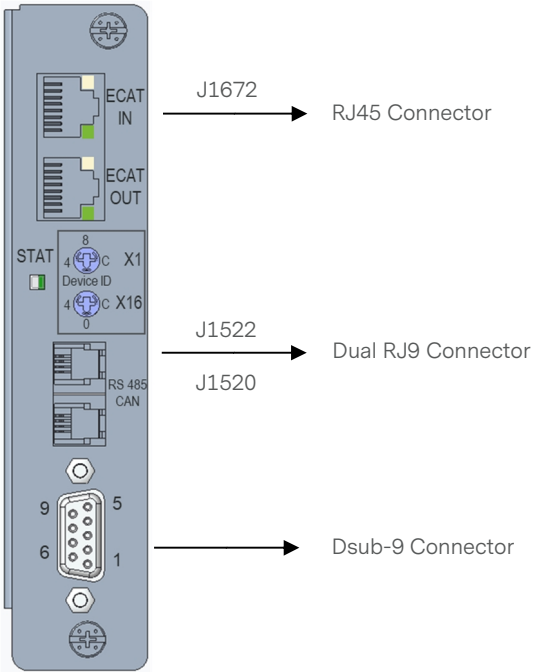

The Location of the Communication Port on Case



iHP12/15



iHP24/30

Communication Interface Support - Optional EtherCAT

Pin Assignment

iHP RACK Connector	Pin Number	Designation	Functions
RJ45 (Ethernet port)	1	TX+_D1	Transmit Data+
	2	TX-_D1	Transmit Data-
	3	RX+_D2	Receive Data+
	4	BI+_D3	Bi-directional+
	5	BI-_D3	Bi-directional-
	6	RX-_D2	Receive Data-
	7	BI+_D4	Bi-directional+
	8	BI-_D4	Bi-directional-
RJ11 (RS485/CAN)	1	CANL	CAN communication lines
	2	CANH	CAN communication lines
	3	NC	-
	4	DGND	Common ground
DSUB9	1	+24V_IN	24V External Power Input Voltage Supply to Power ISOCOMM
	2	RTN	Power/Signal Return
	3	INTLK+	Interlock Open/Short to INTLK-
	4	INTLK-	Interlock Open/Short to INTLK-
	5	+24V_Bias	Signal Input Supply for Interlock Circuit
	6	INTLK_OK	24V Output Indicating that Interlock is Active
	7	AC_OK	Open Collector ACOK Output (24V logic – internally pulled-up to +24V_Bias)
	8	DC_OK	Open Collector DCOK Output (24V logic – internally pulled-up to +24V_Bias)
	9	5V_STBY	5V Standby

Note 1 - The ISOCOMM with EtherCAT supports CAN Bus communications.

Note 2 - J1520 and J1522 serve as ports for CAN Bus ports.

Note 3 - The two RJ9 ports facilitate daisy chain connection in a multiple iHP rack configuration.

Multi-Rack Functionality - EtherCAT

Turn-on Synchronization

To allow for timing and turn-on synchronization, an interlock signal and external +24V_Bias are provisioned on the DB9.

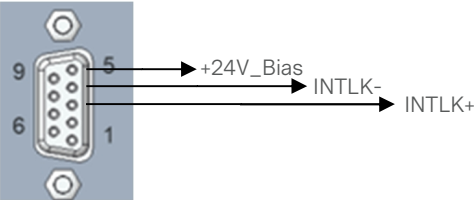

Turn-on Requirements of the ISOCOMM with EtherCAT

To enable the iHP rack, INTLK+ and INTLK- should be shorted and an external 24V should be applied across +24V_IN (pin 1) and RTN (pin 2).

If rack is configured as Master, the rack will only turn-on if all the Slave racks configured with it are present.

If rack is configured as Slave, the rack will only turn on if the Master is present.

AC Input	+24V_Bias	INTLK INTLK+ and INLK- Shorted	RACK Output ON/OFF
OFF	OFF	OPEN	OFF
OFF	OFF	CLOSE	OFF
OFF	ON	OPEN	OFF
OFF	ON	CLOSE	OFF
ON	OFF	OPEN	OFF
ON	OFF	CLOSE	OFF
ON	ON	OPEN	OFF
ON	ON	CLOSE	ON

Turn-on Multi Rack Functionality and Module Grouping

The ISOCOMM with EtherCAT supports multiple rack configuration and module grouping.

Up to three iHP racks could be connected in daisy chain fashion via CAN Bus.

One rack configured as master and 2 racks configured as slaves.

The rack configured as master communicates to the external system via EtherCAT.

Internal rack-to-rack communication is accomplished via the CAN bus.

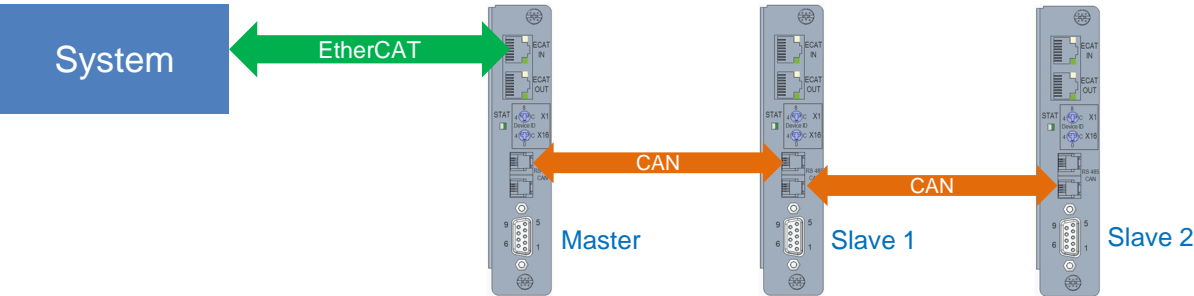

EtherCAT Communication Specification – Object Dictionary

The list below enumerates the EtherCAT supported objects.

Index	Object Code	Name	Data Bytes	Default Value	Access Type
Communication Area					
0x1000	VAR	Device Type	UDINT	0xFFFFFFFF	RO (Read Only)
0x1008	VAR	Device Name	STRING (13)	iHP Rack	RO (Read Only)
0x1009	VAR	Hardware Version	STRING (3)	XXX	RO (Read Only)
0x100A	VAR	Software Version	STRING (7)	XXXXXXX	RO (Read Only)
0x1018	RECORD	Identity		See Identity	RO (Read Only)
PDO Mapping Objects					
0x1600	RECORD	Receive PDOs		See Receive PDOs	RO (Read Only)
0x1A00	RECORD	Transmit PDOs		See Transmit PDOs	RO (Read Only)
Manufacturer Specific Input Area					
0x2000	RECORD	PSU Status		See PSU Status	RO (Read Only)
0x2001	RECORD	Temperature		See Temperature	RO (Read Only)
0x2002	RECORD	Fan		See Fan	RO (Read Only)
0x2003	RECORD	ISOCOMM		See ISOCOMM	RW
0x2004	RECORD	PFC 1		See PFC1	RW
0x2005	RECORD	PFC 2		See PFC2	RW
0x2006	RECORD	Module 1		See Module 1	RW
0x2007	RECORD	Module 2		See Module 2	RW
0x2008	RECORD	Module 3		See Module 3	RW
0x2009	RECORD	Module 4		See Module 4	RW
0x200A	RECORD	Module 5		See Module 5	RW
0x200B	RECORD	Module 6		See Module 6	RW
0x200C	RECORD	Module 7		See Module 7	RW
0x200D	RECORD	Module 8		See Module 8	RW
0x200E	RECORD	Group 1		See Group 1	RW
0x200F	RECORD	Group 2		See Group 2	RW
0x2010	RECORD	Group 3		See Group 3	RW
0x2011	RECORD	Group 4		See Group 4	RW
Manufacturer Specific Output Area					
0x3001	RECORD	Rack Operation		See Rack Operation	RW
Device Specific Information Data					
0xF500	RECORD	Runtime		See Runtime	RO (Read Only)
0xF501	RECORD	Total Runtime		See Total Runtime	RO (Read Only)
0xF502	VAR	EtherCAT Device ID	USINT	N/A	RO (Read Only)
0xF503	RECORD	EtherCAT Communication	STRING(1)	N/A	RO (Read Only)
0xF9F0	VAR	Manufacturer Serial Number	STRING(13)	N/A	RO (Read Only)
0xF9F3	VAR	Vendor Name	STRING(32)	Advanced Energy Industries, Inc.	RO (Read Only)

EtherCAT Communication Specification – Objects

Identity

Index 0x1018

Number of Entries 4

Access Type RO (Read Only)

Sub Index	Data Type	Name	Default Value
0x01	UNIT32	Vendor ID	0x000002B9 (697)
0x02	UNIT32	Product Code	0x25CA12E5 (634000101)
0x03	UNIT32	Revision	0x00000001 (1)
0x04	UNIT32	Serial Number	00000000

Receive PDOs

Index 0x1600

Number of Entries 52

Access Type RO (Read Only)

Sub Index	Data Type	Object Name	Object Index
0x01	BOOL	Communication Watchdog	0xF503:01, 8
0x02	BOOL	Operation	0x2004:01, 8
0x03	BOOL	Write Protection	0x2004:02, 8
0x04	BOOL	Module 1 Operation	0x2007:01, 8
0x05	BOOL	Module 1 Write Protection	0x2007:02, 8
0x06	REAL	Module 1 VREF Trim	0x2007:0A, 32
0x07	REAL	Module 1 IREF Trim	0x2007:0B, 32
0x08	BOOL	Module 2 Operation	0x2008:01, 8
0x09	BOOL	Module 2 Write Protection	0x2008:02, 8
0x0A	REAL	Module 2 VREF Trim	0x2008:0A, 32
0x0B	REAL	Module 2 IREF Trim	0x2008:0B, 32
0x0C	BOOL	Module 3 Operation	0x2009:01, 8
0x0D	BOOL	Module 3 Write Protection	0x2009:02, 8
0x0E	REAL	Module 3 VREF Trim	0x2009:0A, 32
0x0F	REAL	Module 3 IREF Trim	0x2009:0B, 32
0x10	BOOL	Module 4 Operation	0x200A:01, 8
0x11	BOOL	Module 4 Write Protection	0x200A:02, 8
0x12	REAL	Module 4 VREF Trim	0x200A:0A, 32
0x13	REAL	Module 4 IREF Trim	0x200A:0B, 32
0x14	BOOL	Module 5 Operation	0x200B:01, 8
0x15	BOOL	Module 5 Write Protection	0x200B:02, 8
0x16	REAL	Module 5 VREF Trim	0x200B:0A, 32
0x17	REAL	Module 5 IREF Trim	0x200B:0B, 32
0x18	BOOL	Module 6 Operation	0x200C:01, 8
0x19	BOOL	Module 6 Write Protection	0x200C:02, 8
0x1A	REAL	Module 6 VREF Trim	0x200C:0A, 32
0x1B	REAL	Module 6 IREF Trim	0x200C:0B, 32
0x1C	BOOL	Module 7 Operation	0x200D:01, 8
0x1D	BOOL	Module 7 Write Protection	0x200D:02, 8
0x1E	REAL	Module 7 VREF Trim	0x200D:0A, 32
0x1F	REAL	Module 7 IREF Trim	0x200D:0B, 32

EtherCAT Communication Specification – Objects

Sub Index	Data Type	Object Name	Object Index
0x20	BOOL	Module 8 Operation	0x200E:01, 8
0x21	BOOL	Module 8 Write Protection	0x200E:02, 8
0x22	REAL	Module 8 VREF Trim	0x200E:0A, 32
0x23	REAL	Module 8 IREF Trim	0x200E:0B, 32
0x24	BOOL	Group 1 Operation	0x200F:01, 8
0x25	BOOL	Group 1 Write Protection	0x200F:02, 8
0x26	REAL	Group 1 VREF Trim	0x200F:0A, 32
0x27	REAL	Group 1 IREF Trim	0x200F:0B, 32
0x28	BOOL	Group 2 Operation	0x2010:01, 8
0x29	BOOL	Group 2 Write Protection	0x2010:02, 8
0x2A	REAL	Group 2 VREF Trim	0x2010:0A, 32
0x2B	REAL	Group 2 IREF Trim	0x2010:0B, 32
0x2C	BOOL	Group 3 Operation	0x2011:01, 8
0x2D	BOOL	Group 3 Write Protection	0x2011:02, 8
0x2E	REAL	Group 3 VREF Trim	0x2011:0A, 32
0x2F	REAL	Group 3 IREF Trim	0x2011:0B, 32
0x30	BOOL	Group 4 Operation	0x2012:01, 8
0x31	BOOL	Group 4 Write Protection	0x2012:02, 8
0x32	REAL	Group 4 VREF Trim	0x2012:0A, 32
0x33	REAL	Group 4 IREF Trim	0x2012:0B, 32
0x34	BOOL	Global Clear Fault	0x3001:01, 8

Transmit PDOs

Index 0x1A00

Number of Entries 221

Access Type RO (Read Only)

Sub Index	Data Type	Object Name	Object Index
0x01	BOOL	Power ON Status	0x2001:01, 8
..		Remote Interlock Status	0x2001:02, 8
0x04		Output Active Status	0x2001:03, 8
		Local Interlock	0x2001:04, 8
0x5	REAL	PFC Temperature	0x2002:01, 32
0x6	REAL	Ambient Temperature	0x2002:02, 32
0x07	REAL	FAN 1 Speed	0x2003:01, 32
..	
0xA		FAN 4 Speed	0x2003:01, 32
0xB	BOOL	Operation	0x2004:01, 8
0xC	BOOL	Write Protection	0x2004:02, 8
0xD	UNIT16	Status Word	0x2004:03, 16
0xE	REAL	Input Voltage 1	0x2004:04, 32
..		Input Voltage 2	0x2004:05, 32
		Input Voltage 3	0x2004:06, 32
0x13		Input Current 1	0x2004:07, 32
		Input Current 2	0x2004:08, 32
		Input Current 3	0x2004:09, 32

EtherCAT Communication Specification – Objects

Sub Index	Data Type	Object Name	Object Index
0x14	UNIT16	PFC 1 Status Word	0x2005:01, 16
0x15	UNIT16	PFC 2 Status Word	0x2006:01, 16
0x16	BOOL	Module 1 Operation	0x2007:01, 8
0x17	UNIT16	Module 1 Write Protection	0x2007:02, 8
0x18	UNIT16	Module 1 Status Word	0x2007:03, 16
0x19	REAL	Module 1 Output Voltage	0x2007:04, 32
..		Module 1 Output Current	0x2007:05, 32
0x1F		Module 1 Output Power	0x2007:06, 32
		Module 1 Power Device Temperature	0x2007:07, 32
		Module 1 Transformer Temperature	0x2007:08, 32
		Module 1 VREF Trim	0x2007:0A, 32
		Module 1 IREF Trim	0x2007:0B, 32
0x20	UNIT8	Module 1 Load Type	0x2007:0C, 8
..		Module 1 Fault Config	0x2007:0D, 8
0x22		Module 1 Config	0x2007:0E, 8
0x23	REAL	Module 1 OV Limit	0x2007:0F, 32
..		Module 1 OC Limit	0x2007:10, 32
0x26		Module 1 OT Limit	0x2007:11, 32
		Module 1 Resistance	0x2007:12, 32
0x27	BOOL	Module 2 Operation	0x2008:01, 8
0x28	BOOL	Module 2 Write Protection	0x2008:02, 8
0x29	UNIT16	Module 2 Status Word	0x2008:03, 16
0x2A	REAL	Module 2 Output Voltage	0x2008:04, 32
..		Module 2 Output Current	0x2008:05, 32
0x30		Module 2 Output Power	0x2008:06, 32
		Module 2 Power Device Temperature	0x2008:07, 32
		Module 2 Transformer Temperature	0x2008:08, 32
		Module 2 VREF Trim	0x2008:0A, 32
		Module 2 IREF Trim	0x2008:0B, 32
0x31	UNIT8	Module 2 Load Type	0x2008:0C, 8
..		Module 2 Fault Config	0x2008:0D, 8
0x33		Module 2 Config	0x2008:0E, 8
0x34	REAL	Module 2 OV Limit	0x2008:0F, 32
..		Module 2 OC Limit	0x2008:10, 32
0x37		Module 2 OT Limit	0x2008:11, 32
		Module 2 Resistance	0x2008:12, 32
0x38	BOOL	Module 3 Operation	0x2009:01, 8
0x39	BOOL	Module 3 Write Protection	0x2009:02, 8
0x3A	UNIT16	Module 3 Status Word	0x2009:03, 16
0x3B	REAL	Module 3 Output Voltage	0x2009:04, 32
..		Module 3 Output Current	0x2009:05, 32
0x41		Module 3 Output Power	0x2009:06, 32
		Module 3 Power Device Temperature	0x2009:07, 32
		Module 3 Transformer Temperature	0x2009:08, 32
		Module 3 VREF Trim	0x2009:0A, 32
		Module 3 IREF Trim	0x2009:0B, 32

EtherCAT Communication Specification – Objects

Sub Index	Data Type	Object Name	Object Index
0x42	UNIT8	Module 3 Load Type	0x2009:0C, 8
..		Module 3 Fault Config	0x2009:0D, 8
0x44		Module 3 Config	0x2009:0E, 8
0x45	REAL	Module 3 OV Limit	0x2009:0F, 32
..		Module 3 OC Limit	0x2009:10, 32
..		Module 3 OT Limit	0x2009:11, 32
0x48		Module 3 Resistance	0x2009:12, 32
0x49	BOOL	Module 4 Operation	0x200A:01, 8
0x4A	BOOL	Module 4 Write Protection	0x200A:02, 8
0x4B	UNIT16	Module 4 Status Word	0x200A:03, 16
0x4C	REAL	Module 4 Output Voltage	0x200A:04, 32
..		Module 4 Output Current	0x200A:05, 32
..		Module 4 Output Power	0x200A:06, 32
..		Module 4 Power Device Temperature	0x200A:07, 32
..		Module 4 Transformer Temperature	0x200A:08, 32
..		Module 4 VREF Trim	0x200A:0A, 32
0x52		Module 4 IREF Trim	0x200A:0B, 32
0x53	UNIT8	Module 4 Load Type	0x200A:0C, 8
..		Module 4 Fault Config	0x200A:0D, 8
0x55		Module 4 Config	0x200A:0E, 8
0x56	REAL	Module 4 OV Limit	0x200A:0F, 32
..		Module 4 OC Limit	0x200A:10, 32
..		Module 4 OT Limit	0x200A:11, 32
0x59		Module 4 Resistance	0x200A:12, 32
0x5A	BOOL	Module 5 Operation	0x200B:01, 8
0x5B	BOOL	Module 5 Write Protection	0x200B:02, 8
0x5C	UNIT16	Module 5 Status Word	0x200B:03, 16
0x5D	REAL	Module 5 Output Voltage	0x200B:04, 32
..		Module 5 Output Current	0x200B:05, 32
..		Module 5 Output Power	0x200B:06, 32
..		Module 5 Power Device Temperature	0x200B:07, 32
..		Module 5 Transformer Temperature	0x200B:08, 32
..		Module 5 VREF Trim	0x200B:0A, 32
0x63		Module 5 IREF Trim	0x200B:0B, 32
0x64	UNIT8	Module 5 Load Type	0x200B:0C, 8
..		Module 5 Fault Config	0x200B:0D, 8
0x66		Module 5 Config	0x200B:0E, 8
0x67	REAL	Module 5 OV Limit	0x200B:0F, 32
..		Module 5 OC Limit	0x200B:10, 32
..		Module 5 OT Limit	0x200B:11, 32
0x6A		Module 5 Resistance	0x200B:12, 32
0x6B	BOOL	Module 6 Operation	0x200C:01, 8
0x6C	BOOL	Module 6 Write Protection	0x200C:02, 8
0x6D	UNIT16	Module 6 Status Word	0x200C:03, 16

EtherCAT Communication Specification – Objects

Sub Index	Data Type	Object Name	Object Index
0x6E .. 0x74	REAL	Module 6 Output Voltage Module 6 Output Current Module 6 Output Power Module 6 Power Device Temperature Module 6 Transformer Temperature Module 6 VREF Trim Module 6 IREF Trim	0x200C:04, 32 0x200C:05, 32 0x200C:06, 32 0x200C:07, 32 0x200C:08, 32 0x200C:0A, 32 0x200C:0B, 32
0x75 .. 0x77	UNIT8	Module 6 Load Type Module 6 Fault Config Module 6 Config	0x200C:0C, 8 0x200C:0D, 8 0x200C:0E, 8
0x78 .. 0x7B	REAL	Module 6 OV Limit Module 6 OC Limit Module 6 OT Limit Module 6 Resistance	0x200C:0F, 32 0x200C:10, 32 0x200C:11, 32 0x200C:12, 32
0x7C	BOOL	Module 7 Operation	0x200D:01, 8
0x7D	BOOL	Module 7 Write Protection	0x200D:02, 8
0x7E	UNIT16	Module 7 Status Word	0x200D:03, 16
0x7F .. 0x85	REAL	Module 7 Output Voltage Module 7 Output Current Module 7 Output Power Module 7 Power Device Temperature Module 7 Transformer Temperature Module 7 VREF Trim Module 7 IREF Trim	0x200D:04, 32 0x200D:05, 32 0x200D:06, 32 0x200D:07, 32 0x200D:08, 32 0x200D:0A, 32 0x200D:0B, 32
0x86 .. 0x88	UNIT8	Module 7 Load Type Module 7 Fault Config Module 7 Config	0x200D:0C, 8 0x200D:0D, 8 0x200D:0E, 8
0x89 .. 0x8C	REAL	Module 7 OV Limit Module 7 OC Limit Module 7 OT Limit Module 7 Resistance	0x200D:0F, 32 0x200D:10, 32 0x200D:11, 32 0x200D:12, 32
0x8D	BOOL	Module 8 Operation	0x200E:01, 8
0x8E	BOOL	Module 8 Write Protection	0x200E:02, 8
0x8F	UNIT16	Module 8 Status Word	0x200E:03, 16
0x90 .. 0x96	REAL	Module 8 Output Voltage Module 8 Output Current Module 8 Output Power Module 8 Power Device Temperature Module 8 Transformer Temperature Module 8 VREF Trim Module 8 IREF Trim	0x200E:04, 32 0x200E:05, 32 0x200E:06, 32 0x200E:07, 32 0x200E:08, 32 0x200E:0A, 32 0x200E:0B, 32
0x97 .. 0x99	UNIT8	Module 8 Load Type Module 8 Fault Config Module 8 Config	0x200E:0C, 8 0x200E:0D, 8 0x200E:0E, 8

EtherCAT Communication Specification – Objects

Sub Index	Data Type	Object Name	Object Index
0x9A	REAL	Module 8 OV Limit	0x200E:0F, 32
..		Module 8 OC Limit	0x200E:10, 32
0x9D		Module 8 OT Limit	0x200E:11, 32
		Module 8 Resistance	0x200E:12, 32
0x9E	BOOL	Group 1 Operation	0x200F:01, 8
0x9F	BOOL	Group 1 Write Protection	0x200F:02, 8
0xA0	UNIT16	Group 1 Status Word	0x200F:03, 16
0xA1	REAL	Group 1 Temperature	0x200F:04, 32
..		Group 1 Output Voltage	0x200F:05, 32
0xA4		Group 1 Output Current	0x200F:06, 32
		Group 1 Output Power	0x200F:07, 32
0xA5	UNIT8	Group 1 Load Type	0x200F:08, 8
0xA6	UNIT8	Group 1 Config	0x200F:09, 8
0xA7	REAL	Group 1 VREF Trim	0x200F:0A, 32
0xA8	REAL	Group 1 IREF Trim	0x200F:0B, 32
0xA9	UNIT8	Group 1 Members	0x200F:0C, 8
..		Group 1 Type	0x200F:0D, 8
0xAB		Group 1 Number of Modules	0x200F:0E, 8
0xAC	BOOL	Group 2 Operation	0x2010:01, 8
0xAD	BOOL	Group 2 Write Protection	0x2010:02, 8
0xAE	UNIT16	Group 2 Status Word	0x2010:03, 16
0xAF	REAL	Group 2 Temperature	0x2010:04, 32
..		Group 2 Output Voltage	0x2010:05, 32
0xB2		Group 2 Output Current	0x2010:06, 32
		Group 2 Output Power	0x2010:07, 32
0xB3	UNIT8	Group 2 Load Type	0x2010:08, 8
0xB4	UNIT8	Group 2 Config	0x2010:09, 8
0xB5	REAL	Group 2 VREF Trim	0x2010:0A, 32
0xB6	REAL	Group 2 IREF Trim	0x2010:0B, 32
0xB7	UNIT8	Group 2 Members	0x2010:0C, 8
..		Group 2 Type	0x2010:0D, 8
0xB9		Group 2 Number of Modules	0x2010:0E, 8
0xBA	BOOL	Group 3 Operation	0x2011:01, 8
0xBB	BOOL	Group 3 Write Protection	0x2011:02, 8
0xBC	UNIT16	Group 3 Status Word	0x2011:03, 16
0xBD	REAL	Group 3 Temperature	0x2011:04, 32
..		Group 3 Output Voltage	0x2011:05, 32
0xC0		Group 3 Output Current	0x2011:06, 32
		Group 3 Output Power	0x2011:07, 32
0xC1	UNIT8	Group 3 Load Type	0x2011:08, 8
0xC2	UNIT8	Group 3 Config	0x2011:09, 8
0xC3	REAL	Group 3 VREF Trim	0x2011:0A, 32
0xC4	REAL	Group 3 IREF Trim	0x2011:0B, 32
0xC5	UNIT8	Group 3 Members	0x2011:0C, 8
..		Group 3 Type	0x2011:0D, 8
0xC7		Group 3 Number of Modules	0x2011:0E, 8
0xC8	BOOL	Group 4 Operation	0x2012:01, 8
0xC9	BOOL	Group 4 Write Protection	0x2012:02, 8
0xCA	UNIT16	Group 4 Status Word	0x2012:03, 16

EtherCAT Communication Specification – Objects

Sub Index	Data Type	Object Name	Object Index
0xCB	REAL	Group 4 Temperature	0x2012:04, 32
..		Group 4 Output Voltage	0x2012:05, 32
0xCE		Group 4 Output Current	0x2012:06, 32
		Group 4 Output Power	0x2012:07, 32
0xCF	UNIT8	Group 4 Load Type	0x2012:08, 8
0xD0	UNIT8	Group 4 Config	0x2012:09, 8
0xD1	REAL	Group 4 VREF Trim	0x2012:0A, 32
0xD2	REAL	Group 4 IREF Trim	0x2012:0B, 32
0xD3	UNIT8	Group 4 Members	0x2012:0C, 8
..		Group 4 Type	0x2012:0D, 8
0xD5		Group 4 Number of Modules	0x2012:0E, 8
0xD6	BOOL	Global Clear Fault	0x3001:01, 8
0xD7	UNIT8	Module Save	0x3001:02, 8
0xD8	BOOL	Multi-Rack Enable	0x3001:03, 8
0xD9	BOOL	Multi-Rack Master	0x3001:04, 8
0xDA	UNIT8	Slave Count	0x3001:05, 8
0xDB	UNIT8	Rack Address	0x3001:06, 8
0xDC	BOOL	Module Synchronization	0x3001:07, 8
0xDD	BOOL	System Restart	0x3001:08, 8

PSU Status

Description Reports the operational status of the rack

Index 0x2001

Number of Entries 4

Sub Index	Data Type	Access Type	Name	Default Value
0x01	BOOL	Read	Power ON Status	0x00
0x02	BOOL	Read	Remote Interlock Status	0x00
0x03	BOOL	Read	Output Active Status	0x00
0x04	BOOL	Read	Local Interlock	0x00

Temperature

Description Reports Ambient and PFC Temperature

Index 0x2002

Number of Entries 2

Sub Index	Data Type	Access Type	Name	Default Value
0x01	REAL	Read	PFC Temperature	0.000000
0x02	REAL	Read	Ambient Temperature	0.000000

EtherCAT Communication Specification – Objects

Fan

Description Reports FAN RPM

Index 0x2003

Number of Entries 4

Sub Index	Data Type	Access Type	Name	Default Value
0x01	REAL	Read	Fan 1 Speed	0.000000
0x02	REAL	Read	Fan 2 Speed	0.000000
0x03	REAL	Read	Fan 3 Speed	0.000000
0x04	REAL	Read	Fan 4 Speed	0.000000

ISOCOMM

Description Reports rack information, status and input parameters

Index 0x2004

Number of Entries 10

Sub Index	Data Type	Access Type	Name	Default Value
0x01	BOOL	Read/Write	Operation	1
0x02	BOOL	Read/Write	Write Protection	1
0x03	UNIT16	Read	Status Word	0x0000
0x04	REAL	Read	Input Voltage 1	0.000000
0x05	REAL	Read	Input Voltage 2	0.000000
0x06	REAL	Read	Input Voltage 3	0.000000
0x07	REAL	Read	Input Current 1	0.000000
0x08	REAL	Read	Input Current 2	0.000000
0x09	REAL	Read	Input Current 3	0.000000
0x0A	STRING(9)	Read	ISOCOMM Firmware Version	-

PFC 1

Description PFC 1 parameters

Index 0x2005

Number of Entries 2

Sub Index	Data Type	Access Type	Name	Default Value
0x01	UNIT16	Read	Status Word	0x0000
0x02	STRING(9)	Read	PFC 1 Firmware Version	-

PFC 2

Description PFC 2 parameters

Index 0x2006

Number of Entries 2

Sub Index	Data Type	Access Type	Name	Default Value
0x01	UNIT16	Read	Status Word	0x0000
0x02	STRING(9)	Read	PFC 2 Firmware Version	-

EtherCAT Communication Specification – Objects

Module 1

Description Module 1 parameters

Index 0x2007

Number of Entries 19

Sub Index	Data Type	Access Type	Name	Default Value
0x01	BOOL	Read/Write	Operation	1
0x02	BOOL	Read/Write	Write Protection	1
0x03	UNIT16	Read	Status Word	0x0000
0x04	REAL	Read	Output Voltage	0.000000
0x05	REAL	Read	Output Current	0.000000
0x06	REAL	Read	Output Power	0.000000
0x07	REAL	Read	Power Device Temperature	0.000000
0x08	REAL	Read	Transformer Temperature	0.000000
0x09	STRING(13)	Read	Serial Number	-
0x0A	REAL	Read/Write	VREF Trim	0.000000
0x0B	REAL	Read/Write	IREF Trim	0.000000
0x0C	UNIT8	Read/Write	Module Load Type	0x00
0x0D	UNIT8	Read	Fault Config	0x00
0x0E	UNIT8	Read/Write	Module Config	0x00
0x0F	REAL	Read	OV Limit	0.000000
0x10	REAL	Read	OC Limit	0.000000
0x11	REAL	Read	OT Limit	0.000000
0x12	REAL	Read	Resistance	0.000000
0x13	STRING(9)	Read	Module 1 Firmware Version	-

EtherCAT Communication Specification – Objects

Module 2

Description Module 2 parameters

Index 0x2008

Number of Entries 19

Sub Index	Data Type	Access Type	Name	Default Value
0x01	BOOL	Read/Write	Operation	1
0x02	BOOL	Read/Write	Write Protection	1
0x03	UNIT16	Read	Status Word	0x0000
0x04	REAL	Read	Output Voltage	0.000000
0x05	REAL	Read	Output Current	0.000000
0x06	REAL	Read	Output Power	0.000000
0x07	REAL	Read	Power Device Temperature	0.000000
0x08	REAL	Read	Transformer Temperature	0.000000
0x09	STRING(13)	Read	Serial Number	-
0x0A	REAL	Read/Write	VREF Trim	0.000000
0x0B	REAL	Read/Write	IREF Trim	0.000000
0x0C	UNIT8	Read/Write	Module Load Type	0x00
0x0D	UNIT8	Read	Fault Config	0x00
0x0E	UNIT8	Read/Write	Module Config	0x00
0x0F	REAL	Read	OV Limit	0.000000
0x10	REAL	Read	OC Limit	0.000000
0x11	REAL	Read	OT Limit	0.000000
0x12	REAL	Read	Resistance	0.000000
0x13	STRING(9)	Read	Module 2 Firmware Version	-

EtherCAT Communication Specification – Objects

Module 3

Description Module 3 parameters

Index 0x2009

Number of Entries 19

Sub Index	Data Type	Access Type	Name	Default Value
0x01	BOOL	Read/Write	Operation	1
0x02	BOOL	Read/Write	Write Protection	1
0x03	UNIT16	Read	Status Word	0x0000
0x04	REAL	Read	Output Voltage	0.000000
0x05	REAL	Read	Output Current	0.000000
0x06	REAL	Read	Output Power	0.000000
0x07	REAL	Read	Power Device Temperature	0.000000
0x08	REAL	Read	Transformer Temperature	0.000000
0x09	STRING(13)	Read	Serial Number	-
0x0A	REAL	Read/Write	VREF Trim	0.000000
0x0B	REAL	Read/Write	IREF Trim	0.000000
0x0C	UNIT8	Read/Write	Module Load Type	0x00
0x0D	UNIT8	Read	Fault Config	0x00
0x0E	UNIT8	Read/Write	Module Config	0x00
0x0F	REAL	Read	OV Limit	0.000000
0x10	REAL	Read	OC Limit	0.000000
0x11	REAL	Read	OT Limit	0.000000
0x12	REAL	Read	Resistance	0.000000
0x13	STRING(9)	Read	Module 3 Firmware Version	-

EtherCAT Communication Specification – Objects

Module 4

Description Module 4 parameters

Index 0x200A

Number of Entries 19

Sub Index	Data Type	Access Type	Name	Default Value
0x01	BOOL	Read/Write	Operation	1
0x02	BOOL	Read/Write	Write Protection	1
0x03	UNIT16	Read	Status Word	0x0000
0x04	REAL	Read	Output Voltage	0.000000
0x05	REAL	Read	Output Current	0.000000
0x06	REAL	Read	Output Power	0.000000
0x07	REAL	Read	Power Device Temperature	0.000000
0x08	REAL	Read	Transformer Temperature	0.000000
0x09	STRING(13)	Read	Serial Number	-
0x0A	REAL	Read/Write	VREF Trim	0.000000
0x0B	REAL	Read/Write	IREF Trim	0.000000
0x0C	UNIT8	Read/Write	Module Load Type	0x00
0x0D	UNIT8	Read	Fault Config	0x00
0x0E	UNIT8	Read/Write	Module Config	0x00
0x0F	REAL	Read	OV Limit	0.000000
0x10	REAL	Read	OC Limit	0.000000
0x11	REAL	Read	OT Limit	0.000000
0x12	REAL	Read	Resistance	0.000000
0x13	STRING(9)	Read	Module 4 Firmware Version	-

EtherCAT Communication Specification – Objects

Module 5

Description Module 5 parameters

Index 0x200B

Number of Entries 19

Sub Index	Data Type	Access Type	Name	Default Value
0x01	BOOL	Read/Write	Operation	1
0x02	BOOL	Read/Write	Write Protection	1
0x03	UNIT16	Read	Status Word	0x0000
0x04	REAL	Read	Output Voltage	0.000000
0x05	REAL	Read	Output Current	0.000000
0x06	REAL	Read	Output Power	0.000000
0x07	REAL	Read	Power Device Temperature	0.000000
0x08	REAL	Read	Transformer Temperature	0.000000
0x09	STRING(13)	Read	Serial Number	-
0x0A	REAL	Read/Write	VREF Trim	0.000000
0x0B	REAL	Read/Write	IREF Trim	0.000000
0x0C	UNIT8	Read/Write	Module Load Type	0x00
0x0D	UNIT8	Read	Fault Config	0x00
0x0E	UNIT8	Read/Write	Module Config	0x00
0x0F	REAL	Read	OV Limit	0.000000
0x10	REAL	Read	OC Limit	0.000000
0x11	REAL	Read	OT Limit	0.000000
0x12	REAL	Read	Resistance	0.000000
0x13	STRING(9)	Read	Module 5 Firmware Version	-

EtherCAT Communication Specification – Objects

Module 6

Description Module 6 parameters

Index 0x200C

Number of Entries 19

Sub Index	Data Type	Access Type	Name	Default Value
0x01	BOOL	Read/Write	Operation	1
0x02	BOOL	Read/Write	Write Protection	1
0x03	UNIT16	Read	Status Word	0x0000
0x04	REAL	Read	Output Voltage	0.000000
0x05	REAL	Read	Output Current	0.000000
0x06	REAL	Read	Output Power	0.000000
0x07	REAL	Read	Power Device Temperature	0.000000
0x08	REAL	Read	Transformer Temperature	0.000000
0x09	STRING(13)	Read	Serial Number	-
0x0A	REAL	Read/Write	VREF Trim	0.000000
0x0B	REAL	Read/Write	IREF Trim	0.000000
0x0C	UNIT8	Read/Write	Module Load Type	0x00
0x0D	UNIT8	Read	Fault Config	0x00
0x0E	UNIT8	Read/Write	Module Config	0x00
0x0F	REAL	Read	OV Limit	0.000000
0x10	REAL	Read	OC Limit	0.000000
0x11	REAL	Read	OT Limit	0.000000
0x12	REAL	Read	Resistance	0.000000
0x13	STRING(9)	Read	Module 6 Firmware Version	-

EtherCAT Communication Specification – Objects

Module 7

Description Module 7 parameters

Index 0x200D

Number of Entries 19

Sub Index	Data Type	Access Type	Name	Default Value
0x01	BOOL	Read/Write	Operation	1
0x02	BOOL	Read/Write	Write Protection	1
0x03	UNIT16	Read	Status Word	0x0000
0x04	REAL	Read	Output Voltage	0.000000
0x05	REAL	Read	Output Current	0.000000
0x06	REAL	Read	Output Power	0.000000
0x07	REAL	Read	Power Device Temperature	0.000000
0x08	REAL	Read	Transformer Temperature	0.000000
0x09	STRING(13)	Read	Serial Number	-
0x0A	REAL	Read/Write	VREF Trim	0.000000
0x0B	REAL	Read/Write	IREF Trim	0.000000
0x0C	UNIT8	Read/Write	Module Load Type	0x00
0x0D	UNIT8	Read	Fault Config	0x00
0x0E	UNIT8	Read/Write	Module Config	0x00
0x0F	REAL	Read	OV Limit	0.000000
0x10	REAL	Read	OC Limit	0.000000
0x11	REAL	Read	OT Limit	0.000000
0x12	REAL	Read	Resistance	0.000000
0x13	STRING(9)	Read	Module 7 Firmware Version	-

EtherCAT Communication Specification – Objects

Module 8

Description Module 8 parameters

Index 0x200E

Number of Entries 19

Sub Index	Data Type	Access Type	Name	Default Value
0x01	BOOL	Read/Write	Operation	1
0x02	BOOL	Read/Write	Write Protection	1
0x03	UNIT16	Read	Status Word	0x0000
0x04	REAL	Read	Output Voltage	0.000000
0x05	REAL	Read	Output Current	0.000000
0x06	REAL	Read	Output Power	0.000000
0x07	REAL	Read	Power Device Temperature	0.000000
0x08	REAL	Read	Transformer Temperature	0.000000
0x09	STRING(13)	Read	Serial Number	-
0x0A	REAL	Read/Write	VREF Trim	0.000000
0x0B	REAL	Read/Write	IREF Trim	0.000000
0x0C	UNIT8	Read/Write	Module Load Type	0x00
0x0D	UNIT8	Read	Fault Config	0x00
0x0E	UNIT8	Read/Write	Module Config	0x00
0x0F	REAL	Read	OV Limit	0.000000
0x10	REAL	Read	OC Limit	0.000000
0x11	REAL	Read	OT Limit	0.000000
0x12	REAL	Read	Resistance	0.000000
0x13	STRING(9)	Read	Module 8 Firmware Version	-

EtherCAT Communication Specification – Objects

Group 1

Description Group 1 parameters

Index 0x200F

Number of Entries 14

Sub Index	Data Type	Access Type	Name	Default Value
0x01	BOOL	Read/Write	Operation	1
0x02	BOOL	Read/Write	Write Protection	1
0x03	UNIT16	Read	Status Word	0x0000
0x04	REAL	Read	Temperature	0.00
0x05	REAL	Read	Output Voltage	0.00
0x06	REAL	Read	Output Current	0.00
0x07	REAL	Read	Output Power	0.00
0x08	UNIT8	Read/Write	Module Load Type	0x00
0x09	UNIT8	Read/Write	Module Config	0x00
0x0A	REAL	Read/Write	VREF Trim	0.00
0x0B	REAL	Read/Write	IREF Trim	0.00
0x0C	UNIT8	Read/Write	Group Members	0x00
0x0D	UNIT8	Read/Write	Group Type	0x00
0x0E	UNIT8	Read	Number of Modules	0x00

Group 2

Description Group 2 parameters

Index 0x2010

Number of Entries 14

Sub Index	Data Type	Access Type	Name	Default Value
0x01	BOOL	Read/Write	Operation	1
0x02	BOOL	Read/Write	Write Protection	1
0x03	UNIT16	Read	Status Word	0x0000
0x04	REAL	Read	Temperature	0.00
0x05	REAL	Read	Output Voltage	0.00
0x06	REAL	Read	Output Current	0.00
0x07	REAL	Read	Output Power	0.00
0x08	UNIT8	Read/Write	Module Load Type	0x00
0x09	UNIT8	Read/Write	Module Config	0x00
0x0A	REAL	Read/Write	VREF Trim	0.00
0x0B	REAL	Read/Write	IREF Trim	0.00
0x0C	UNIT8	Read/Write	Group Members	0x00
0x0D	UNIT8	Read/Write	Group Type	0x00
0x0E	UNIT8	Read	Number of Modules	0x00

EtherCAT Communication Specification – Objects

Group 3

Description Group 3 parameters

Index 0x2011

Number of Entries 14

Sub Index	Data Type	Access Type	Name	Default Value
0x01	BOOL	Read/Write	Operation	1
0x02	BOOL	Read/Write	Write Protection	1
0x03	UNIT16	Read	Status Word	0x0000
0x04	REAL	Read	Temperature	0.00
0x05	REAL	Read	Output Voltage	0.00
0x06	REAL	Read	Output Current	0.00
0x07	REAL	Read	Output Power	0.00
0x08	UNIT8	Read/Write	Module Load Type	0x00
0x09	UNIT8	Read/Write	Module Config	0x00
0x0A	REAL	Read/Write	VREF Trim	0.00
0x0B	REAL	Read/Write	IREF Trim	0.00
0x0C	UNIT8	Read/Write	Group Members	0x00
0x0D	UNIT8	Read/Write	Group Type	0x00
0x0E	UNIT8	Read	Number of Modules	0x00

Group 4

Description Group 4 parameters

Index 0x2012

Number of Entries 14

Sub Index	Data Type	Access Type	Name	Default Value
0x01	BOOL	Read/Write	Operation	1
0x02	BOOL	Read/Write	Write Protection	1
0x03	UNIT16	Read	Status Word	0x0000
0x04	REAL	Read	Temperature	0.00
0x05	REAL	Read	Output Voltage	0.00
0x06	REAL	Read	Output Current	0.00
0x07	REAL	Read	Output Power	0.00
0x08	UNIT8	Read/Write	Module Load Type	0x00
0x09	UNIT8	Read/Write	Module Config	0x00
0x0A	REAL	Read/Write	VREF Trim	0.00
0x0B	REAL	Read/Write	IREF Trim	0.00
0x0C	UNIT8	Read/Write	Group Members	0x00
0x0D	UNIT8	Read/Write	Group Type	0x00
0x0E	UNIT8	Read	Number of Modules	0x00

EtherCAT Communication Specification – Objects

Rack Operation

Description Global Clear Fault, Module Save

Index 0x3001

Number of Entries 8

Sub Index	Data Type	Access Type	Name	Default Value
0x01	BOOL	Read/Write	Global Clear Fault	0
0x02	BOOL	Read/Write	Module Save	0
0x03	BOOL	Read/Write	Multi-Rack Enable	0
0x04	BOOL	Read/Write	Multi-Rack Master	0
0x05	BOOL	Read/Write	Slave Count	0
0x06	BOOL	Read/Write	Rack Address	0
0x07	BOOL	Read/Write	Module Synchronization	0
0x08	BOOL	Read/Write	System Restart	0

Runtime

Description Shows the time since restarted

Index 0xF500

Number of Entries 6

Sub Index	Data Type	Access Type	Name	Default Value
0x01	UNIT8	Read	Year	0
0x02	UNIT8	Read	Month	0
0x03	UNIT8	Read	Day	0
0x04	UNIT8	Read	Hour	0
0x05	UNIT8	Read	Minute	0
0x06	UNIT8	Read	Second	0

Total Runtime

Description Shows the time since first powered up

Index 0xF501

Number of Entries 6

Sub Index	Data Type	Access Type	Name	Default Value
0x01	UNIT8	Read	Year	0
0x02	UNIT8	Read	Month	0
0x03	UNIT8	Read	Day	0
0x04	UNIT8	Read	Hour	0
0x05	UNIT8	Read	Minute	0
0x06	UNIT8	Read	Second	0

Record of Revision and Changes

Issue	Date	Description	Originators
1.0	07.24.2017	First Issue	A. Zhang
1.1	11.28.2019	Update the command list	A. Zhang
1.2	09.20.2023	Update format issue and Remove E7 command	K. Wang
1.3	11.05.2025	Add description for optional ISOCOMM board with EtherCAT starting from page 49	A. Zhang



For international contact information,
visit advancedenergy.com.

powersales@aei.com (Sales Support)
productsupport.ep@aei.com (Technical Support)
+1 888 412 7832

ABOUT ADVANCED ENERGY

Advanced Energy (AE) has devoted more than three decades to perfecting power for its global customers. AE designs and manufactures highly engineered, precision power conversion, measurement and control solutions for mission-critical applications and processes.

Our products enable customer innovation in complex applications for a wide range of industries including semiconductor equipment, industrial, manufacturing, telecommunications, data center computing, and medical. With deep applications know-how and responsive service and support across the globe, we build collaborative partnerships to meet rapid technological developments, propel growth for our customers, and innovate the future of power.

PRECISION | POWER | PERFORMANCE

Specifications are subject to change without notice. Not responsible for errors or omissions. ©2020 Advanced Energy Industries, Inc. All rights reserved. Advanced Energy®, and AE® are U.S. trademarks of Advanced Energy Industries, Inc.